

**sanitary diaphragm seal
threaded process connection
DIN, SMS, RJT/APV, IDF/ISS**

MGS9/SA



Diaphragm seals are designed to isolate the sensing element of pressure gauges and pressure switches from process fluids which may be corrosive, viscous, sedimentous and/or with a high temperature. The diaphragm is welded to the upper body, to ensure separation of filling fluid from process medium. Designed in accordance with food and pharmaceutical standards to permit easy removal from the plant whilst maintains the hygienic feature during frequent cleaning.

4.SAN - MGS9/SA

Working pressure: from 0...30 to 0...600 psi (from 0...1 to 0...40 bar). Minimum working pressure as from MINIMUM RANGES table .

Process temperature: -4...+248°F (-20°C...+120°C).

Accuracy*: (add to instrument accuracy) ±0,5% for direct mounting.

Instrument connection: AISI 316 st.st..

Diaphragm: welded,

4 - AISI 316 L st.st.

Filling liquid: mineral oil (FDA approved) for food industry.

Process connection: AISI 316 (Cod. 4)st.st. as per:

-DIN 11851;

-SMS 681;

-RJT / APV;

-IDF / ISS;

see "MINIMUM RANGES" table for dimensions.

Union nut: AISI 304 st.st.

MINIMUM RANGES

Process connection		Female with union nut			Male		
		DS 2.5" (63mm)	DS 4" (100mm)	DS 6" (150mm)	DS 2.5" (63mm)	DS 4" (100mm)	DS 6" (150mm)
DIN 11851	25	0...60 psi (0...4 bar)	0...60 psi (0...4 bar)	0...100 psi (0...6 bar)	0...100 psi (0...6 bar)		
	32		0...60 psi (0...4 bar)	0...100 psi (0...6 bar)		0...60 psi (0...4 bar)	0...100 psi (0...6 bar)
	40		0...30 psi (0...1,6 bar)	0...60 psi (0...2,5 bar)		0...60 psi (0...4 bar)	0...100 psi (0...6 bar)
	50		0...15 psi (0...1 bar)	0...30 psi (0...1,6 bar)		0...30 psi (0...1,6 bar)	0...60 psi (0...2,5 bar)
SMS 681	1" 1/2		0...60 psi (0...4 bar)	0...100 psi (0...6 bar)		0...60 psi (0...4 bar)	0...100 psi (0...6 bar)
	2"		0...30 psi (0...1,6 bar)	0...60 psi (0...2,5 bar)		0...30 psi (0...1,6 bar)	0...60 psi (0...2,5 bar)
RJT/APV	1" 1/2		0...60 psi (0...4 bar)	0...100 psi (0...6 bar)		0...60 psi (0...4 bar)	0...100 psi (0...6 bar)
	2"		0...30 psi (0...1,6 bar)	0...60 psi (0...2,5 bar)		0...30 psi (0...1,6 bar)	0...60 psi (0...2,5 bar)
IDF/ISS	1" 1/2		0...60 psi (0...4 bar)	0...100 psi (0...6 bar)		0...60 psi (0...4 bar)	0...100 psi (0...6 bar)
	2"		0...30 psi (0...1,6 bar)	0...60 psi (0...2,5 bar)		0...30 psi (0...1,6 bar)	0...60 psi (0...2,5 bar)

* at 68°F (20 °C) process temperature (or state temperature when ordering)

Female with union nut

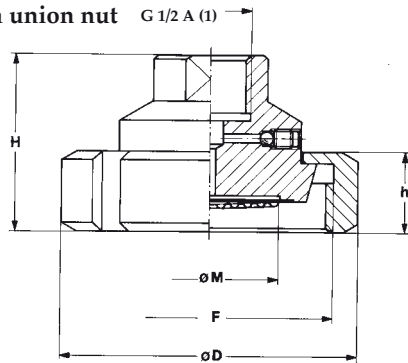

(1) DN 25 = G 1/2 A, G 1/4 A; 1" = G 1/4 A

Male

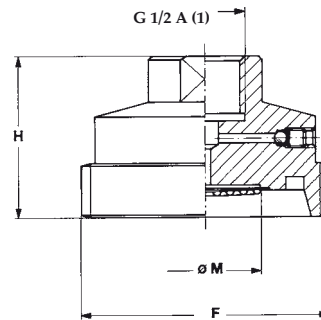

(1) DN 25 and 1" = G 1/4 A

DIN 11851 - (example draw below)

DN	Code	H	h	D	M	F (DIN 405)
25	QHF	*1.81" (*46)	0.82" (21)	2.48" (63)	1.18" (30)	Rd 52 x 1/6
32	RHF	1.81" (46)	0.82" (21)	2.75" (70)	1.18" (30)	Rd 58 x 1/6
40	SHF	1.81" (46)	0.82" (21)	3.07" (78)	1.57" (40)	Rd 65 x 1/6
50	THF	1.85" (47)	0.86" (22)	3.62" (92)	1.96" (50)	Rd 78 x 1/6

(*) G 1/4 A: 1.63" (41,5 mm)

dimensions : inches (mm)

DIN 11851 - (example draw below)

DN	Code	H	M	F (DIN 405)
25	QHM	1.45" (37)	0.78" (20)	Rd 52 x 1/6
32	RHM	1.65" (42)	1.18" (30)	Rd 58 x 1/6
40	SHM	1.65" (42)	1.18" (30)	Rd 65 x 1/6
50	THM	1.65" (42)	1.57" (40)	Rd 78 x 1/6

SMS

DN	Code	H	h	D	M	F (DIN 405)
1" 1/2	AIF	1.94"	0.98"	2.91"	1.18"	Rd 60 x 1/6
2"	BIF	1.98"	1.02"	3.30"	1.57"	Rd 70 x 1/6

SMS

DN	Code	H	M	F (DIN 405)
1" 1/2	AIM	1.69"	1.18"	Rd 60 x 1/6
2"	BIM	1.69"	1.57"	Rd 70 x 1/6

RJT/APV

DN	Code	H	h	D	M	F (Withworth)
1" 1/2	ALF	1.94"	0.86"	Ex. 2.55"	1.18"	2" 5/16 x 8
2"	BLF	1.94"	0.86"	Ex. 3.11"	1.57"	2" 7/8 x 6

RJT/APV

DN	Code	H	M	F (Withworth)
1" 1/2	ALM	1.83"	1.18"	2" 5/16 x 8
2"	BLM	1.83"	1.57"	2" 7/8 x 6

IDF/ISS

DN	Code	H	h	D	M	F (ACME)
1" 1/2	AMF	2.14"	1.18"	2.51"	1.18"	2" 1/32 x 8
2"	BMF	2.14"	1.18"	3.03"	1.57"	2" 9/16 x 8

IDF/ISS

DN	Code	H	M	F (ACME)
1" 1/2	AMM	1.75"	1.18"	2" 1/32 x 8
2"	BMM	1.75"	1.57"	2" 9/16 x 8

dimensions : inches

ASSEMBLING

All diaphragm seals are mounted on the instruments and fixed by an aluminium protection label.

D - Direct
T - Cooling extension

OPTIONS

C05 - Helium Test
P04 - Dye penetrant test

"HOW TO ORDER" SEQUENCE

Section/Model/Connection material/Diaphragm material/Process Connection/Instrument connection/Assembling/Options
4 SAN 4 4 QHF...THM 41F - G 1/2 F D, T C05, P04
AIF...BIM
ALF...BLM
AMF...BMM