

MEASURING INSTRUMENTS - STRUMENTI PER MISURARE

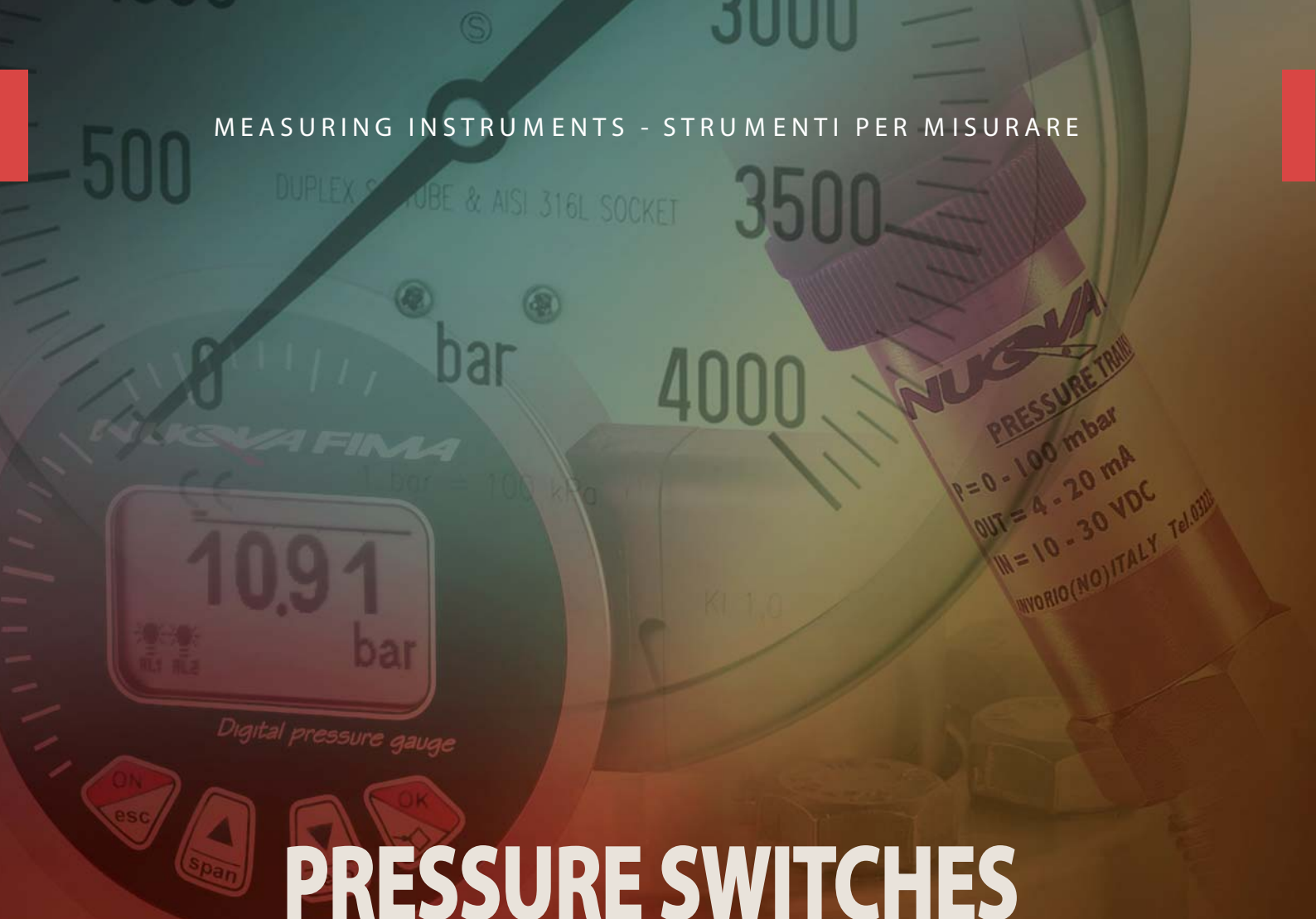

PRESSURE SWITCHES

NUOVA FIMA

diaphragm pressure switch



PED 2014/68/EU

These diaphragm pressure switches are IP 55, and only suitable for applications in the chemical, petrochemical and conventional power plants. The sensing element is a metallic diaphragm and acts directly on the microswitch through a self-centering pivot. The simplicity of the design, without levers, cams or similar mechanism, gives the unit an exceptionally long working life.

3.10 - Standard Model

Ranges: 0...1 bar/0...25 bar; -1...0 bar.

Electrical specifications: N. 1 SPDT microswitches. (see microswitches table)

Differential: fixed.

Repeatability: ≤ 1% of the full setting value.

Set-point adjustment: internal, micrometric adjustable.

Protection: IP 55 as per EN 60529/IEC 529.

Cable exit: cable gland (cables ø 0.24...0.43" - 6...11 mm).

Electrical wiring: terminal screw, directly on microswitch.

Earth contacts: N. 1 internal.

Process temperature: +212°F max (100°C).

Ambient temperature: -13...+149°F (-25...+65 °C).

Thermal drift: ≤ 0,027% / °F (≤ 0,05% / °C).

Process connection: anticorodal aluminium blue anodized, 1/4" NPT F.

Elastic element: AISI 316 st.st. diaphragm for pressure ranges ≤ 2,5 bar; carbon steel diaphragm covered with AISI 316 st.st. for pressure ranges 4...25 bar.

Gasket: PTFE.

Case: anticorodal aluminium blue anodized.

Cover: anticorodal aluminium yellow anodized.

Tag: AISI 304 st.st. silk-screen painted.

Weight: 1.87 (0,85 kg).

Setting ranges	Test pressure	Differential 1 MICRO (2)
0,05...1 bar (1)	1,3 bar	40 mbar
0,05...1,6 bar (1)	2 bar	40 mbar
0,06...2,5 bar (1)	3 bar	50 mbar
0,08...4 bar	5 bar	60 mbar
0,12...6 bar	8 bar	100 mbar
0,15...10 bar	12 bar	120 mbar
0,25...16 bar	20 bar	200 mbar
0,4...25 bar	30 bar	300 mbar

(1) available also for vacuum & compound.

(2) differential and minimum set-point values for microswitches cod. I, N, S, U are 300% of those shown in table.

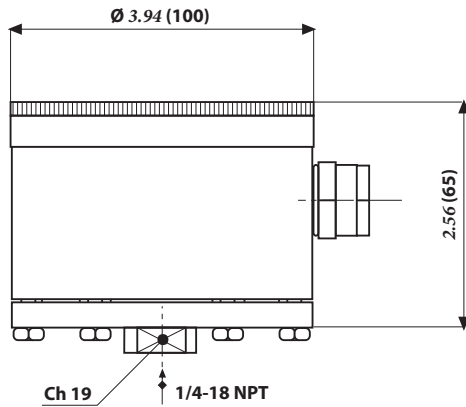

dimensions : inches (mm)

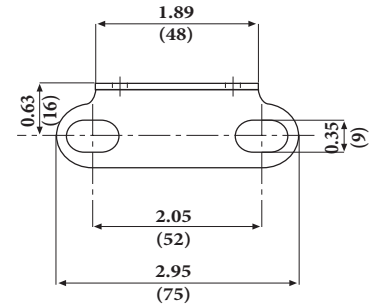
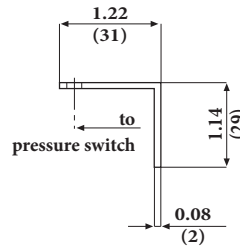

Walls mounting bracket (Cod. **S16**)

Set-point adjustment

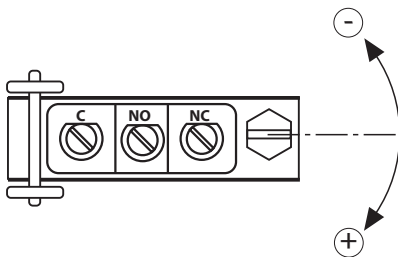

MICROSWITCHES
ohmic load

Single	Type	250	125	24
		Vac	Vac	Vdc
C	std.	15A	15A	0,1A
G	SPLASH	15A	15A	0,1A
I	goldplated		1A	0,1A
M	inert gas filled	15A	15A	0,1A
N	goldplated and inert gas filled		1A	0,1A
S	SPLASH VDC	15A	15A	6A
U	inert gas filled VDC	15A	15A	6A

”HOW TO ORDER” SEQUENCE

Section / Model / Set-point Adjustment / Microswitch / Electrical connection / Process connection /Options
3 10 **C, G** --- **23F - 1/4 NPT F S16**
I, M
N
S, U



diaphragm pressure switch



These diaphragm pressure switches are IP 55, and suitable for a variety of applications such as: chemical, petrochemical and conventional power station. They withstand the most unfavourable working conditions, caused by either the process fluid aggressiveness or high ambient temperature.

3.20 - Standard Model

Ranges: 0...1 bar/0...25 bar.

Electrical specifications: N. 1 SPDT microswitch (see microswitches table).

Differential: fixed (adjustable 10%...50% of setting range (see microswitches table).

Repeatability: $\leq 1\%$ of the full setting value.

Set point adjustment: internal, micrometric adjustable.

Protection: IP 55 as per EN 60529/IEC 529.

Electrical wiring: terminal screw, directly on microswitch.

Earth contacts: N. 1 internal, N. 1 external.

Process temperature: +212°F max (100°C).

Ambient temperature: -13...+149°F (-25...+65 °C).

Thermal drift: $\leq 0,027\% / ^\circ F$ ($\leq 0,05\% / ^\circ C$).

Process connection: AISI 316L st.st.

Elastic element: AISI 316 Ti st.st. diaphragm, welded.

Case: aluminium, blue polyurethane painted.

Cover: aluminium beige polyurethane painted.

Tag: AISI 304 st.st., silk-screen painted.

Weight: 4.73 lbs (1,15 kg).

Setting range	Test pressure	Differential 1 micro (1)
0,06...1 bar	1,5 ap	40 мбар
0,1...2,5 bar	3 ap	60 мбар
0,1...4 bar	5 ap	70 мбар
0,15...6 bar	8 ap	100 мбар
0,2...10 bar	13 ap	120 мбар
0,3...16 bar	20 ap	200 мбар
0,4...25 bar	30 ap	350 мбар

(1) differential and minimum set-point values for microswitches cod. I, N, S, U are 300% of those shown in table.

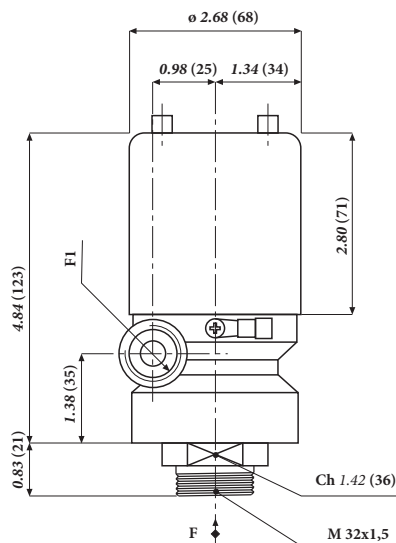

dimensions : inches (mm)

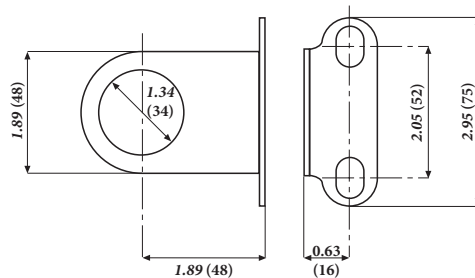

F1		F	
1	R 1/2-ISO 7/1	41M	G 1/2 B
3	1/2-14 NPT	43M	1/2-14 NPT
P11	cable gland	23F	R 1/4-18 NPT F

Set-point adjustment

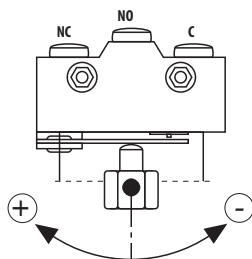

MICROSWITCHES
ohmic load

Single	Type	250	125	24
		Vac	Vac	Vdc
C	std.	15A	15A	0,1A
G	SPLASH	15A	15A	0,1A
I	goldplated		1A	0,1A
M	inert gas filled	15A	15A	0,1A
N	goldplated and inert gas filled		1A	0,1A
E	adjustable dead band	20A	20A	0,1A
S	SPLASH VDC	15A	15A	6A
U	inert gas filled VDC	15A	15A	6A

OPTIONS

P02 - Degreasing for oxygen
S16 - Mounting bracket
T01 - Tropicalisation
V20 - Epoxy painting

”HOW TO ORDER” SEQUENCE

Section / Model / Set-point Adjustment / Microswitch / Electrical connection / Process connection / Options

3 **20** **C, G** **1** **41M** **P02...V20**
I, M **3** **43M**
N, E **P11** **23F**
S, U



diaphragm pressure switch



PED 2014/68/EU

These diaphragm pressure switches are IP 55, and suitable for a variety of applications such as: chemical, petrochemical and conventional power station. They withstand the most unfavourable working conditions, caused by either the process fluid aggressiveness or high ambient temperature.

3.25 - Standard Model

Ranges: 0...40 mbar/0...600 mbar.

Electrical specifications: N. 1 SPDT microswitches. (see microswitches table)

Differential: fixed.

Ripeatability: ≤1% of the full setting value.

Set point adjustment: internal, micrometric adjustable.

Protection: IP 55 as per EN 60529/IEC 529

Electrical wiring: terminal screw, directly on microswitch.

Earth contacts: N. 1 internal, N. 1 external.

Process temperature: +212°F max (100°C).

Ambient temperature: -13...+149°F (-25...+65 °C).

Thermal drift: ≤ 0,027% / °F (≤ 0,05% / °C).

Process connection: AISI 316L st.st.

Elastic element: AISI 316 Ti st.st. diaphragm.

Gasket: PTFE

Case: aluminium, blue polyurethane painted.

Cover: aluminium, beige polyurethane painted.

Tag: stainless steel, silk-screen painted.

Weight: 6.61 lbs (3 kg).

Setting range	Test pressure	Differential 1 micro (1)
5...40 mbar	0,5 bar	4 mbar
5...60 mbar	0,5 bar	4 mbar
5...100 mbar	0,5 bar	4 mbar
8...160 mbar	0,5 bar	6 mbar
8...250 mbar	1 bar	6 mbar
15...400 mbar	1 bar	10 mbar
15...600 mbar	1 bar	10 mbar

(1) differential and minimum set-point values for microswitches cod. I, N, S, U are 300% of those shown in table.

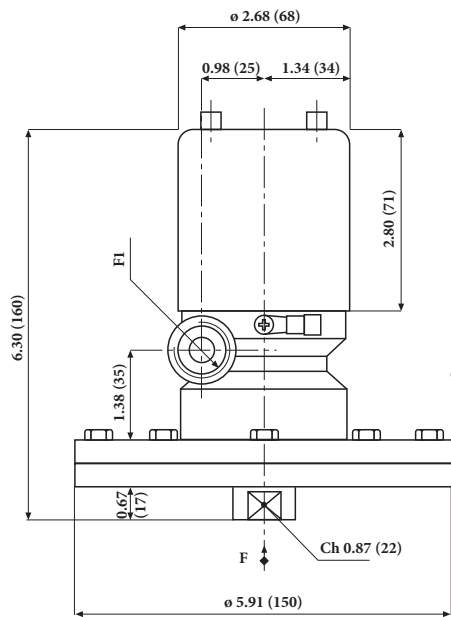

dimensions : inches (mm)

F1	
1	- R 1/2-ISO 7/1
3	- 1/2-14 NPT
P11	- cable gland

F	
43F	- R 1/2-18 NPT F
43M	- 1/2-14 NPT
41M	- G 1/2 B

Set-point adjustment

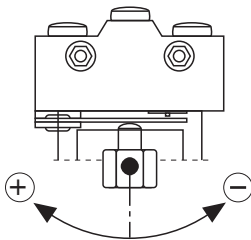

MICROSWITCHES
ohmic load

Single	Type	250	125	24
		Vac	Vac	Vdc
C	std.	15A	15A	0,1A
G	SPLASH	15A	15A	0,1A
I	goldplated		1A	0,1A
M	inert gas filled	15A	15A	0,1A
N	goldplated and inert gas filled		1A	0,1A
S	SPLASH VDC	15A	15A	6A
U	inert gas filled VDC	15A	15A	6A

OPTIONS

P02 - Degreasing for oxygen
S16 - Wall mounting bracket
T01 - Tropicalisation
V20 - Epoxy painting

”HOW TO ORDER” SEQUENCE

Section / Model / Set-point Adjustment / Microswitch / Electrical connection / Process connection /Options

3 25 C, G I, M N, E S, U 1 3 P11 41M 43M 43F P02...V20



diaphragm pressure switch



PED 2014/68/EU

These diaphragm pressure switches are IP 65, and suitable for a variety of applications such as: chemical, petrochemical, conventional power station, and they withstand the most unfavourable working conditions, caused by either the process fluid aggressiveness or high ambient temperature. The sensing element is a metallic diaphragm and acts directly on the microswitch through a self-centering pivot. The simplicity of the design, without levers, cams or similar mechanism, gives the unit an exceptionally long working life.

3.27 - Standard Model

Electrical specifications: N. 1...2 SPDT microswitches (see microswitches table).

Differential: fixed (adjustable 10%...50% of setting range for pressure ranges ≥ 1 bar (see microswitches table).

Repeatability: $\leq 1\%$ of the full setting value.

Set-point adjustment: internal, micrometric adjustable.

Protection: IP 65 as per EN 60529/IEC 529.

Electrical wiring: terminal strip.

Earth contact: N. 1 internal.

Process temperature: $+212^{\circ}\text{F}$ max (100°C).

Ambient temperature: $-13...+149^{\circ}\text{F}$ ($-25...+65^{\circ}\text{C}$).

Thermal drift: $\leq 0,027\% / ^{\circ}\text{F}$ ($\leq 0,05\% / ^{\circ}\text{C}$).

Process connection: AISI 316 st.st.

Elastic element: AISI 316 st.st. diaphragm for pressure ranges $\leq 2,5$ bar; carbon steel diaphragm covered with AISI 316 st.st. for pressure ranges 4...100 bar.

Gasket: PTFE.

Case: AISI 304 st.st.

Cover: AISI 304 st.st., bayonet lock.

Tag: AISI 304 st.st., etched.

Setting range	Test pressure	Special overrange (cod. F03)	Differential 1 micro (2)	Differential 2 micro (2)
0,7...6 mbar (1)	10 mbar		0,5 mbar	
1...16 mbar (1)	20 mbar		0,8 mbar	
2...25 mbar (1)	30 mbar		1,2 mbar	
5...40 mbar (1)	0,5 bar	400 mbar	4 mbar	5 mbar
5...60 mbar (1)	0,5 bar	600 mbar	4 mbar	5 mbar
6...100 mbar (1)	0,5 bar	1 bar	4 mbar	6 mbar
9...160 mbar (1)	0,5 bar	1,6 bar	6 mbar	9 mbar
9...250 mbar (1)	1 bar	2,5 bar	6 mbar	9 mbar
15...400 mbar (1)	1 bar	4 bar	10 mbar	15 mbar
18...600 mbar (1)	1 bar	6 bar	12 mbar	18 mbar
0,06...1 bar (1)	1,2 bar	10 bar	25 mbar	60 mbar
0,06...1,6 bar (1)	2 bar	16 bar	30 mbar	60 mbar
0,06...2,5 bar (1)	3 bar	25 bar	40 mbar	60 mbar
0,08...4 bar	5 bar	40 bar	50 mbar	80 mbar
0,09...6 bar	8 bar	40 bar	60 mbar	90 mbar
0,15...10 bar	12 bar	40 bar	100 mbar	150 mbar
0,25...16 bar	20 bar	40 bar	160 mbar	250 mbar
0,4...25 bar	30 bar	40 bar	250 mbar	400 mbar
0,6...40 bar	48 bar	60 bar	400 mbar	600 mbar
0,9...60 bar	70 bar	80 bar	600 mbar	900 mbar
6...100 bar	120 bar		4 bar	6 bar
8...160 bar	185 bar		5 bar	8 bar

(1) also available for vacuum and compound

(2) differential and minimum set-point values for microswitches cod. I, L, N, R, S, T, U, V are 300% of those shown in table.

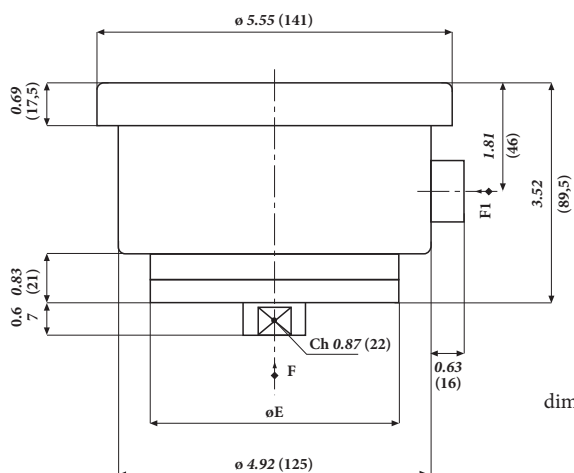

dimensions : inches (mm)

Setting ranges	E	Weight : lbs (kg)
≤ 600 mbar	5.91 (150)	7.27 (3,3)
≥ 1 bar	3.86 (98)	5.05 (2,3)

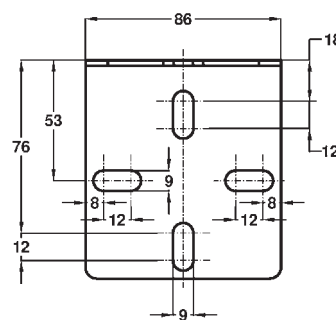
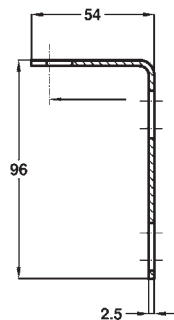

F
23F - 1/4-18 NPT F
43M - 1/2-14 NPT
43F - 1/2-14 NPT F
41M - G 1/2 A

F1
1 - R 1/2-ISO 7/1
2 - R 3/4-ISO 7/1
3 - 1/2-14 NPT
4 - 3/4-14 NPT
A - M20 x 1,5
P11 - cable gland

Set-point adjustment

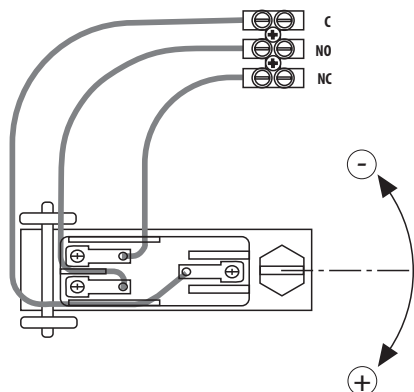

MICROSWITCHES
ohmic load

Single / Double	Type	250	125	24
		Vac	Vac	Vdc
C/D	std.	15A	15A	0,1A
G/H	SPLASH (1)	15A	15A	0,1A
I/L	goldplated (1)		1A	0,1A
M/P	inert gas filled (1)	15A	15A	0,1A
N/R	goldplated and inert gas filled (1)		1A	0,1A
E	adjustable dead band (2)	20A	20A	0,1A
S/T	SPLASH VDC (1)	15A	15A	6A
U/V	inert gas filled VDC (1)	15A	15A	6A

(1) for pressure ranges ≥ 40 mbar
(2) for pressure ranges ≥ 1 bar

OPTIONS

F03 - Special overpressure stop	E30 - Nace MR 01.03 version (1)
M26 - PTFE diaphragm	M23 - Monel diaphragm
S16 - Wall mounting bracket	M22 - Hastelloy C diaphragm
T01 - Tropicalization	M29 - Tantalum diaphragm
P02 - Oxygen service	S31 - 2"stake's mounting bracket

(1) Monel or Hastelloy C diaphragm.

"HOW TO ORDER" SEQUENCE

Section / Model / Set-point Adjustment / Microswitch / Electrical connection / Process connection /Options

3	27	A, B, G, H	1	23F	F03...S31
		I, L, M, P	2	43M	
		N, R, E	3	43F	
		S, T, U, V	4	41M	
			A		
			P11		

Copyright © Nuova Fima srl. All rights reserved. Any part of this publication should not be reproduced without a written Nuova Fima's srl approval



differential pressure switches



PED 2014/68/EU

These differential pressure switches are IP 65, and suitable for a variety of applications such as: chemical, petrochemical, conventional power station where it is required to control differential pressure, level, flow. The sensing element is a metallic diaphragm with 2 metallic bellows and acts directly on the microswitch through a self-centering pivot. The simplicity of the design, without levers, cams or similar mechanism, gives the unit an exceptionally long working life.

3.28 - Standard Model

Ranges: 0...1 bar/0...10 bar.

Electrical specifications: N. 1...2 SPDT microswitches (see microswitches table).

Differential: fixed (adjustable 10%...50% of setting range (see microswitches table).

Repeatability: $\leq 1\%$ of the full setting value.

Set-point adjustment: internal, micrometric adjustable.

Protection: IP 65 as per EN60529/IEC 529.

Electrical wiring: terminal strip.

Earth contacts: N. 1 internal.

Process temperature: $+212^{\circ}\text{F}$ max (100°C).

Ambient temperature: $-13...+149^{\circ}\text{F}$ ($-25...+65^{\circ}\text{C}$).

Thermal drift: $\leq 0,027\% / ^{\circ}\text{F}$ ($\leq 0,05\% / ^{\circ}\text{C}$).

Process connection: AISI 316 st. st.

Elastic element: AISI 316 st.st. diaphragm with N.2 AISI 321 st.st. bellows; PTFE gasket.

Case: AISI 304 st.st.

Cover: AISI 304 st.st. bayonet lock.

Flushing plugs: AISI 316 st.st.

Tag: AISI 304 st.st., etched.

Weight: 8.15 lbs (3,7 kg).

Setting ranges	One side static pressure	Both side static pressure	Differential 1 micro (1)	Differential 2 micro (1)
0,1...1 bar	10 bar	25 bar	60 mbar	80 mbar
0,1...2,5 bar	15 bar	25 bar	60 mbar	80 mbar
0,2...4 bar	15 bar	25 bar	70 mbar	100 mbar
0,2...6 bar	15 bar	25 bar	100 mbar	150 mbar
0,2...10 bar	15 bar	25 bar	120 mbar	170 mbar

(1) differential and minimum set-point values for microswitches cod. I, L, N, R, S, T, U, V are 300% of those shown in table.

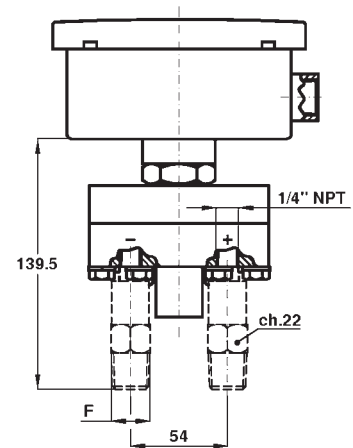
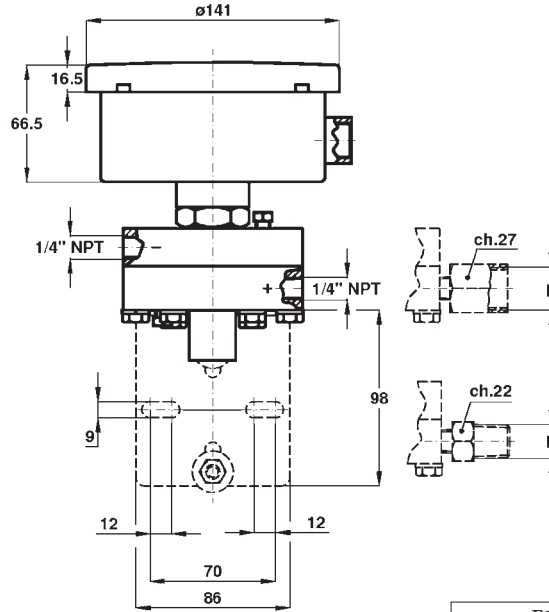
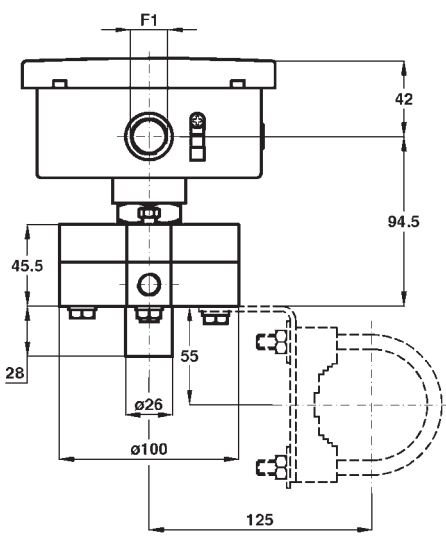

F	
23F	1/4-18 NPT F
43M	1/2-14 NPT
43F	1/2-14 NPT F
41M	G 1/2 A

dimensions : mm

F1	
1	R 1/2-ISO 7/1
2	R 3/4-ISO 7/1
3	1/2-14 NPT
4	3/4-14 NPT
A	M20 x 1,5
P11	cable gland

Set-point adjustment

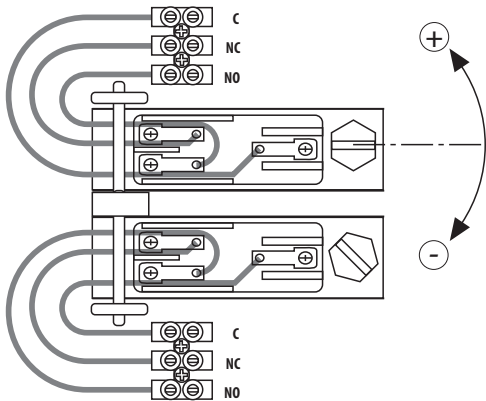

MICROSWITCHES
ohmic load

Single/ Double	Type	250	125	24
		Vac	Vac	Vdc
C/D	std.	15A	15A	0,1A
G/H	SPLASH	15A	15A	0,1A
I/L	goldplated		1A	0,1A
M/P	inert gas filled	15A	15A	0,1A
N/R	goldplated and inert gas filled		1A	0,1A
E/F	adjustable dead band	20A	20A	0,1A
S/T	SPLASH VDC	15A	15A	6A
U/V	inert gas filled VDC	15A	15A	6A

OPTIONS

APV	Lower connection
P02	Degreasing for oxygen
S31	2" stake's mounting bracket
T01	Tropicalisation

"HOW TO ORDER" SEQUENCE

Section / Model / Set-point Adjustment / Microswitch / Electrical connection / Process connection / Options

3 28 A, B, G, H I, L, M, P N, R, E, F S, T, U, V 1 2 3 4 A P11 APV P02...T01 23F 43M 43F 41M



differential pressure switches



PED 2014/68/EU

These differential pressure switches are IP 65, and suitable for a variety of applications such as: chemical, petrochemical, conventional power station where it is required to control differential pressure, level, flow. The sensing element is a metallic diaphragm with 2 metallic bellows and acts directly on the microswitch through a self-centering pivot. The simplicity of the design, without levers, cams or similar mechanism, gives the unit an exceptionally long working life.

3.29 - Standard Model

Ranges: 0...250 mbar/0...600 mbar.

Electrical specifications: N. 1...2 SPDT microswitches (see microswitches table).

Differential: fixed.

Repeatability: $\leq 1\%$ of the full setting value.

Set-point adjustment: internal, micrometric adjustable.

Protection: IP 65 as per EN 60529/IEC 529.

Electrical wiring: terminal strip.

Earth contacts: N. 1 internal.

Process temperature: $+212^{\circ}\text{F}$ max (100°C).

Ambient temperature: $-13...+149^{\circ}\text{F}$ ($-25...+65^{\circ}\text{C}$).

Thermal drift: $\leq 0,027\% / ^{\circ}\text{F}$ ($\leq 0,05\% / ^{\circ}\text{C}$).

Process connection: AISI 316 st. st.

Elastic element: AISI 316 st.st. diaphragm with N.2 AISI 321 st.st. bellows; PTFE gasket.

Case: AISI 304 st.st.

Cover: AISI 304 st.st. bayonet lock.

Flushing plugs: AISI 316 st.st.

Tag: AISI 304 st.st., etched.

Weight: 13.66 lbs (6,2 kg).

Setting ranges	One side static pressure	Both side static pressure	Differential 1 micro (1)	Differential 2 micro (1)
20...250 mbar	2,5 bar	4 bar	10 mbar	15 mbar
25...400 mbar	4 bar	4 bar	16 mbar	20 mbar
35...600 mbar	4 bar	4 bar	20 mbar	30 mbar

(1) differential and minimum set-point values for microswitches cod. I, L, N, R, S, T, U, V are 300% of those shown in table.

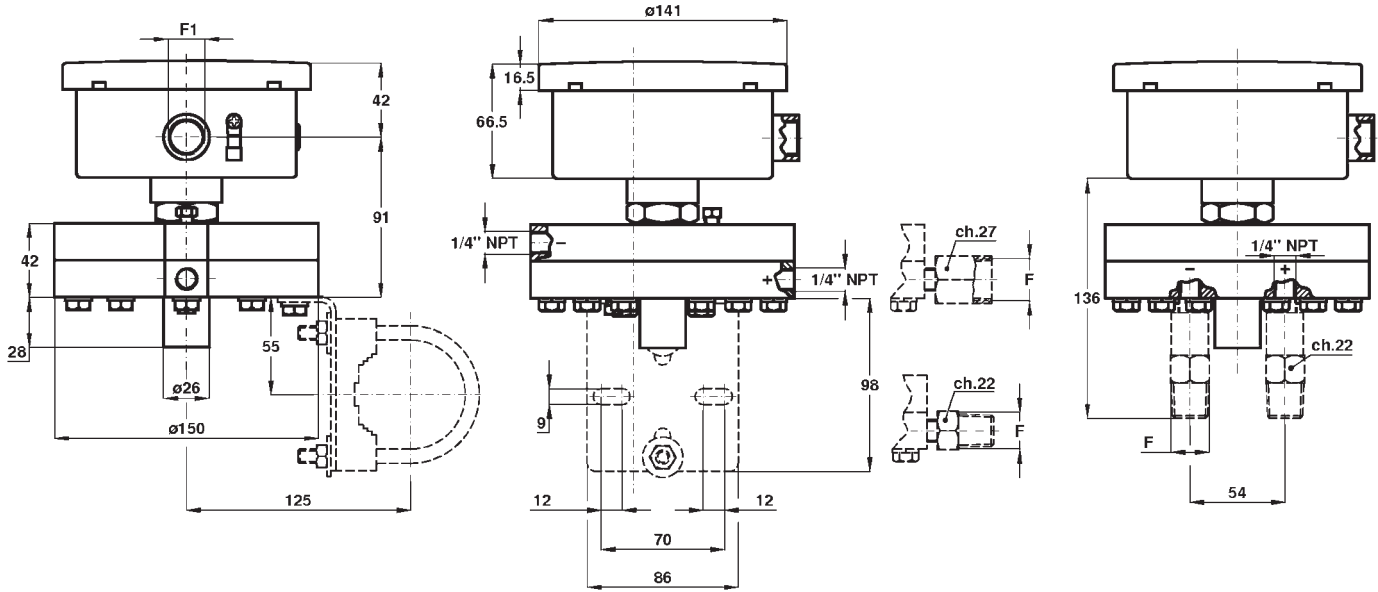

F
23F - 1/4-18 NPT F
43M - 1/2-14 NPT
43F - 1/2-14 NPT F
41M - G 1/2 A

dimensions : mm

F1
1 - R 1/2-ISO 7/1
2 - R 3/4-ISO 7/1
3 - 1/2-14 NPT
4 - 3/4-14 NPT
A - M20 x 1,5
P11 - cable gland

Set-point adjustment

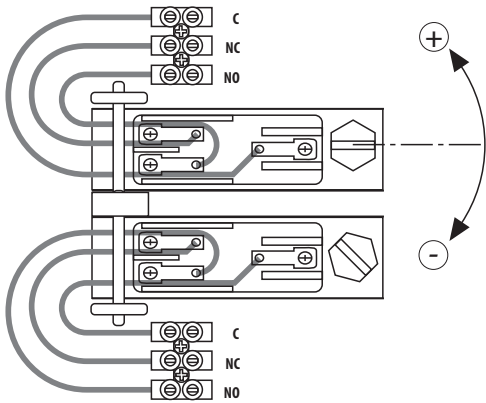

MICROSWITCHES
ohmic load

Single / Double	Type	250	125	24
		Vac	Vac	Vdc
C/D	std.	15A	15A	0,1A
G/H	SPLASH	15A	15A	0,1A
I/L	goldplated		1A	0,1A
M/P	inert gas filled	15A	15A	0,1A
N/R	goldplated and inert gas filled		1A	0,1A
S/T	SPLASH VDC	15A	15A	6A
U/V	inert gas filled VDC	15A	15A	6A

OPTIONS

APV - Lower connection
P02 - Degreasing for oxygen
S31 - 2° stake's mounting bracket
T01 - Tropicalisation

"HOW TO ORDER" SEQUENCE

Section / Model / Set-point Adjustment / Microswitch / Electrical connection / Process connection /Options
3 **29** **A, B, G, H** **1** **APV** **P02...T01**
I, L, M, P **2** **23F**
N, R **3** **43M**
S, T, U, V **4** **43F**
A **41M**
P11

Copyright © Nuova Fima srl. All rights reserved. Any part of this publication should not be reproduced without a written Nuova Fima's srl approval



bourdon tube pressure switch



PED 2014/68/EU

These bourdon tube pressure switches are IP 55, and suitable for a variety of applications such as: chemical, petrochemical, conventional power station where the operating pressure is middle-high. They withstand the most unfavourable working conditions, caused by either the process fluid aggressiveness or high ambient temperature.

3.30 - Standard Model

Ranges: 0...10/0...600 bar.

Electrical specifications: N. 1...2 SPDT microswitches (see microswitches table)

Differential: fixed, or adjustable 10%...50% of setting range (see microswitches tables).

Repeatability: $\leq 1\%$ of the full setting value.

Set-point adjustment: internal but also external accessible, micrometric adjustable.

Protection: IP 55 as per EN 60529/IEC 529.

Electrical wiring: terminal strip.

Earth contacts: N. 1 internal, N. 1 external.

Process temperature: *max* 302°F (150°C).

Ambient temperature: -13...+149°F (-25...+65 °C).

Thermal drift: $\leq 0,027\% / ^\circ F$ ($\leq 0,05\% / ^\circ C$).

Process connection: AISI 316L st. st.

Elastic element: AISI 316L st.st. seamless tube.

Case: aluminium, blue polyurethane painted.

Cover: aluminium, beige polyurethane painted.

Tag: AISI 304 st.st. silk-screen printed.

Weight: 4.62 lbs (2,1 kg).

Setting ranges	Test pressures	Differential 1 micro (1)	Differential 2 micros (1)
0,4...10 bar	15 bar	0,2 bar	0,3 bar
0,7...16 bar	25 bar	0,25 bar	0,5 bar
0,7...25 bar	35 bar	0,3 bar	0,5 bar
1...40 bar	60 bar	0,5 bar	0,7 bar
1,5...60 bar	80 bar	1 bar	1,3 bar
2...100 bar	135 bar	1,4 bar	1,8 bar
4...160 bar	210 bar	2,2 bar	2,9 bar
6...250 bar	350 bar	3,5 bar	4 bar
8...400 bar	500 bar	5 bar	6 bar
10...600 bar	800 bar	7 bar	8 bar

(1) differential and minimum set-point values for microswitches cod. I, L, N, R, S, T, U, V are 300% of those shown in table.

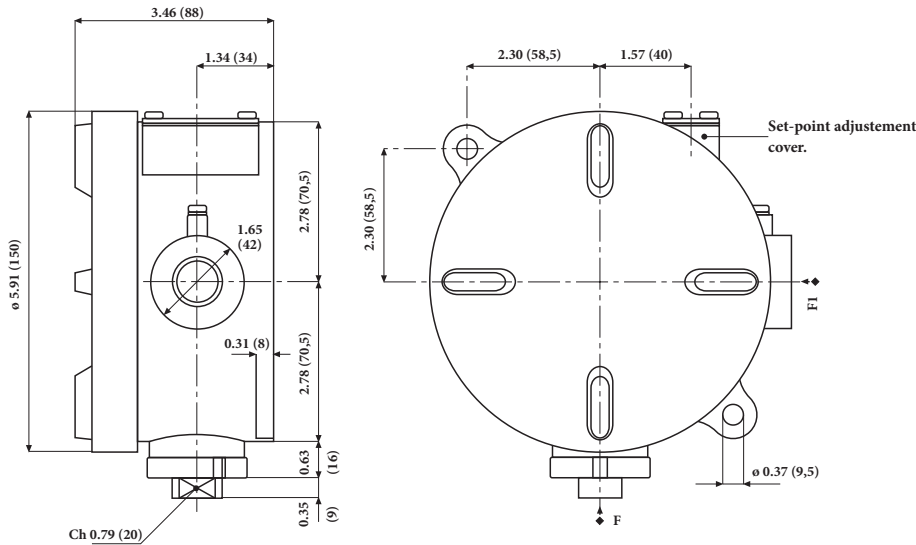

(dimensions : mm)

F1	
1	R 1/2-ISO 7/1
2	R 3/4-ISO 7/1
3	1/2-14 NPT
4	3/4-14 NPT
P11	cable gland

F	
41M	G 1/2 B
43M	1/2-14 NPT
23F	1/4-18 NPT F
43F	1/2-14 NPT F

Set-point adjustment

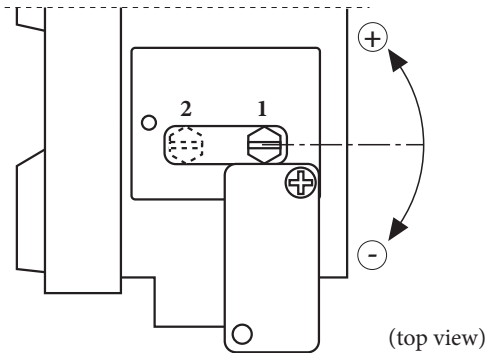

(top view)

MICROSWITCHES
ohmic load

Single / Double	Type	250	125	24
		Vac	Vac	Vdc
C/D	std.	15A	15A	0,1A
G/H	SPLASH	15A	15A	0,1A
I / L	goldplated		1A	0,1A
M/P	inert gas filled	15A	15A	0,1A
N/R	goldplated and inert gas filled		1A	0,1A
E	adjustable dead band	20A	20A	0,1A
S/T	SPLASH VDC	15A	15A	6A
U/V	inert gas filled VDC	15A	15A	6A

OPTIONS

P02	Degreasing for oxygen
S31	2"stake's mounting bracket
V20	Epoxy painting
T01	Tropicalisation

"HOW TO ORDER" SEQUENCE

Section / Model / Set-point Adjustment / Microswitch / Electrical connection / Process connection /Options

3	30	C, D, G, H	1	41M	P02...T01
		I, L, M, P	2	43M	
		N, R, E	3	23F	
		S, T, U, V	4	43F	
			A		



diaphragm pressure switches ATEX flameproof enclosure



**Certificate :
0425 ATEX 2634**



These flameproof electrical apparatus comply with European Directive ATEX 2014/34/EU, for group II and category 2 GD. They are suitable for a variety of uses in hazardous zones 1, 2, 21 and 22 in which the use of flameproof instrument is required. The sensing element is a metallic diaphragm and acts directly on the microswitch through a self-centering pivot. The simplicity of the design, without levers, cams or similar mechanisms, gives the unit an exceptionally long working life.

3.40

Type of ignition protection as per EN 60079-0 and EN 60079-1:
Ex db IIC T6 Ex tb IIIC T85°C.

Protection: IP 65 as per EN 60529.

Ranges: 0...1 bar/0...160 bar; -1...0 bar.

Electrical specifications: N. 1...2 SPDT microswitches, or N.1 with adjustable differential (see microswitches table).

Differential: fixed, or adjustable 10%...50% of setting range (see microswitches table).

Repeatability: ≤ 1% of the full setting value.

Set-point adjustment: internal, micrometric adjustable.

Earth contacts: N. 1 internal, N. 1 external.

Process fluid temperature: -4...+140°F (-20...+60 °C).

Ambient temperature: -4...+149°F (-20...+65 °C).

Thermal drift: ≤ 0,027% / °F (≤ 0,05% / °C).

Process connection: AISI 316 L st.st.

Elastic element: AISI 316 st.st. diaphragm for pressure ranges ≤ 2,5 bar; carbon steel diaphragm covered with AISI 316 L st.st. for pressure ranges > 2,5 bar. Diaphragm PTFE gasket.

Case: aluminium, blue polyurethane painted.

Cover: aluminium, beige polyurethane painted.

Tag: AISI 304 st.st., etched.

Tell-tale vents: polypropylene.

Weight: 6.39 lbs (2,9 kg).

Setting ranges	Test pressure	Special overrange (cod. F03)	Differential 1 micro (2)	Differential 2 micro (2)
0,06...1 bar (1)	1,2 bar	10 bar	25 mbar	60 mbar
0,06...1,6 bar (1)	2 bar	10 bar	30 mbar	60 mbar
0,06...2,5 bar (1)	3 bar	10 bar	40 mbar	60 mbar
0,08...4 bar	5 bar	15 bar	50 mbar	80 mbar
0,09...6 bar	8 bar	15 bar	60 mbar	90 mbar
0,15...10 bar	12 bar	20 bar	100 mbar	150 mbar
0,25...16 bar	20 bar	30 bar	160 mbar	250 mbar
0,4...25 bar	30 bar	35 bar	250 mbar	400 mbar
0,6...40 bar	48 bar	60 bar	400 mbar	600 mbar
0,9...60 bar	70 bar	80 bar	600 mbar	900 mbar
6...100 bar	120 bar		4 bar	6 bar
8...160 bar	185 bar		5 bar	8 bar

(1) also available for vacuum and compound

(2) differential and minimum set-point values for microswitches cod. I, L, N, R, S, T, U, V are 300% of those shown in table.

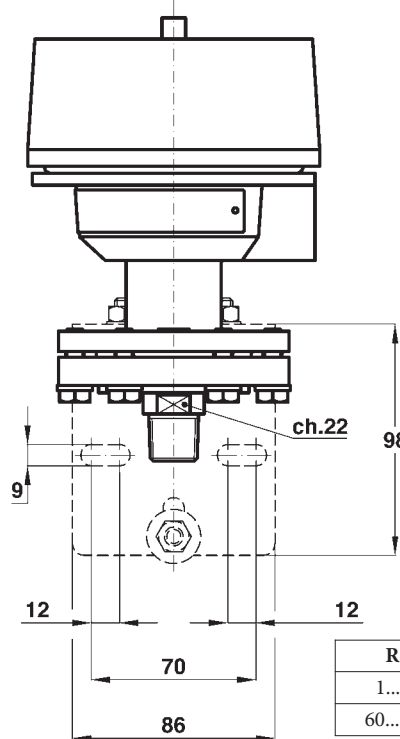
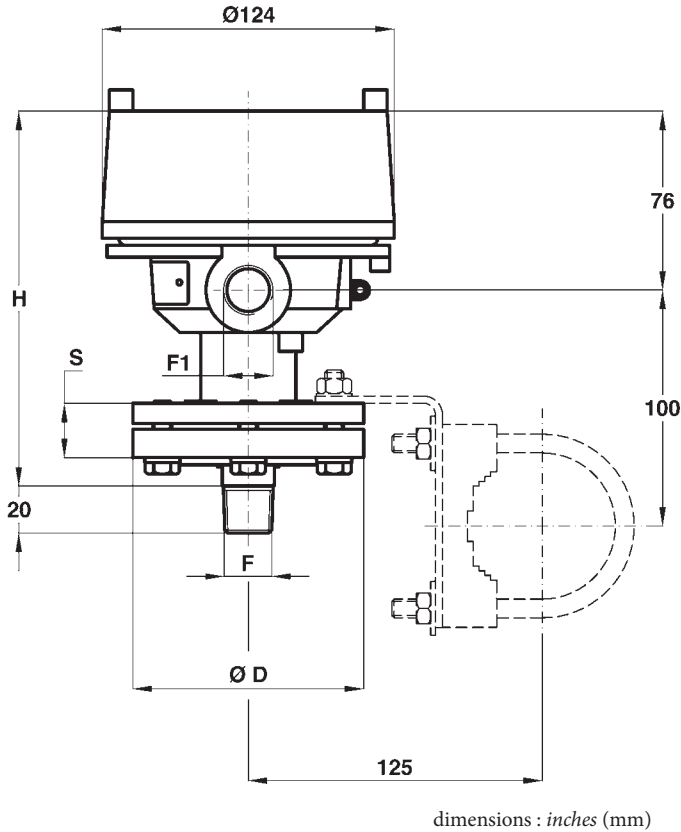

F1	
1	R 1/2-ISO 7/1
2	R 3/4-ISO 7/1
3	1/2-14 NPT
4	3/4-14 NPT
A	M20 x 1,5

F	
41M	G 1/2 B
43M	1/2-14 NPT
53M	3/4-14 NPT
97M	M20 x 1,5

Range			
1...40 bar	98	23	160
60...160 bar	110	41	178

IN ORDER TO IMPROVE THEIR PRODUCTION, MESSRS. NUOVA FIMA RESERVE THE RIGHT TO THEMSELVES TO MAKE ALL THE MODIFICATIONS THAT THEY DEEM INDISPENSABLE AT ANY TIME. UPDATED DATA SHEETS ARE AVAILABLE ON SITE: www.nuovafima.com

Set- point adjustment

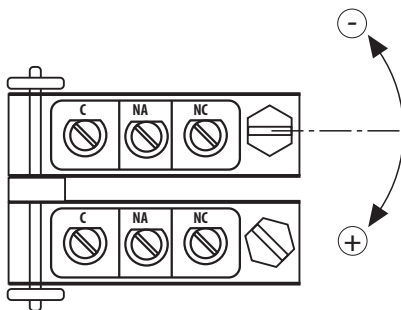

MICROSWITCHES
ohmic load

Single / Double	Type	250	125	24
		Vac	Vac	Vdc
C/D	std.	15A	15A	0,1A
G/H	SPLASH	15A	15A	0,1A
I/L	goldplated		1A	0,1A
M/P	inert gas filled	15A	15A	0,1A
N/R	goldplated and inert gas filled		1A	0,1A
E	adjustable dead band	20A	20A	0,1A
S/T	SPLASH VDC	15A	15A	2A
U/V	inert gas filled VDC	15A	15A	2A

OPTIONS

F03 - Special overpressure stop	E30 - Nace MR 01.03 version (1)
M26 - PTFE diaphragm	M23 - Monel diaphragm
S16 - Wall mounting bracket	M22 - Hastelloy C diaphragm
T01 - Tropicalization	M29 - Tantalum diaphragm
P02 - Oxygen service	S31 - 2"stake's mounting bracket

(1) Monel or Hastelloy C diaphragm.

"HOW TO ORDER" SEQUENCE

Section	Model	Set-point Adjustment	Microswitch	Electrical connection	Process connection	ATEX	Options
3	40	C, D, G, H I, L, M, P N, R, E S, T, U, V	1 2 3 4 A	41M 43M 53M 97M	2D2	F03...S31	



diaphragm pressure switches ATEX flameproof enclosure



**Certificate :
0425 ATEX 2634**

CE
PED 2014/68/EU



II 2 GD Ex db IIC T6 Ex tb IIIC T85°C

These flameproof electrical apparatus comply with European Directive ATEX 2014/34/EU, for group II and category 2 GD. They are suitable for a variety of uses in hazardous zones 1, 2, 21 and 22 in which the use of flameproof instrument is required. The sensing element is a metallic diaphragm and acts directly on the microswitch through a self-centering pivot. The simplicity of the design, without levers, cams or similar mechanisms, gives the unit an exceptionally long working life.

3.42 - Standard Model

Type of ignition protection as per EN 60079-0 and EN 60079-1:
Ex db IIC T6 Ex tb IIIC T85°C.

Protection: IP 65 as per EN 60529.

Ranges: 0...1 bar/0...160 bar; -1...0 bar.

Electrical specifications: N. 1...2 SPDT microswitches, or N.1 with adjustable differential (see microswitches table).

Differential: fixed, or adjustable 10%...50% of setting range (see microswitches table).

Repeatability: ≤ 1% of the full setting value.

Set-point adjustment: internal, micrometric adjustable.

Earth contacts: N. 1 internal, N. 1 external.

Process fluid temperature: -4...+140°F (-20...+60 °C).

Ambient temperature: -4...+149°F (-20...+65 °C).

Thermal drift: ≤ 0,027% / °F (≤ 0,05% / °C).

Process connection: AISI 316 st.st.

Elastic element: AISI 316 st.st. diaphragm for pressure ranges ≤ 2,5 bar; carbon steel diaphragm covered with AISI 316 st.st. for pressure ranges > 2,5 bar. Diaphragm PTFE gasket.

Case: aluminium, blue polyurethane painted.

Cover: aluminium, beige polyurethane painted.

Tag: AISI 304 st.st., etched.

Tell-tale vents: polypropylene.

Set-point ranges	Test pressure	Special overrange (cod. F03)	Differential 1 micro (2)	Differential 2 micro (2)
0,06...1 bar (1)	1,2 bar	10 bar	25 mbar	60 mbar
0,06...1,6 bar (1)	2 bar	10 bar	30 mbar	60 mbar
0,06...2,5 bar (1)	3 bar	10 bar	40 mbar	60 mbar
0,08...4 bar	5 bar	15 bar	50 mbar	80 mbar
0,09...6 bar	8 bar	15 bar	60 mbar	90 mbar
0,15...10 bar	12 bar	20 bar	100 mbar	150 mbar
0,25...16 bar	20 bar	30 bar	160 mbar	250 mbar
0,4...25 bar	30 bar	35 bar	250 mbar	400 mbar
0,6...40 bar	48 bar	60 bar	400 mbar	600 mbar
0,9...60 bar	70 bar	80 bar	600 mbar	900 mbar
6...100 bar	120 bar		4 bar	6 bar
8...160 bar	185 bar		5 bar	8 bar

(1) also available for vacuum and compound

(2) differential and minimum set-point values for microswitches cod. I, L, N, R, S, T, U, V are 300% of those shown in table.

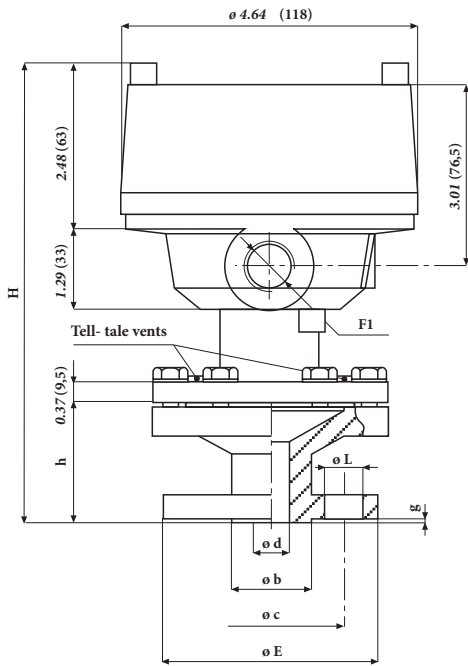

dimensions : inches (mm)

UNI - DIN STANDARDS (1)

dimensions : mm

Code	DN(2)	PN-bar	h	H	E	b	d	g	c	L(3)
OOO	15	6	46	188	80	40	15	2	55	11,5
OQO	15	10...16	50	192	95	45	15	2	65	14
OSO	15	25...40	52	194	95	45	15	2	65	14
QOO	25	6	49	191	100	60	25	2	75	11,5
QQO	25	10...16	59	201	115	68	25	2	85	14
QSO	25	25...40	59	201	115	68	25	2	85	14

ASME STANDARDS (1)

dimensions : inches

Code	DN(2)	Class	h	H	E	b	d			L(3)
4AA	1/2"	150	1.89	7.48	3.50	1.38	0.59	0.06	2.38	0.63
4BA	1/2"	300	2.11	7.70	3.74	1.38	0.59	0.06	2.64	0.63
4DA	1/2"	600	2.36	7.95	3.74	1.38	0.59	0.25	2.64	0.63
6AA	1"	150	2.01	7.60	4.25	2	0.98	0.06	3.13	0.63
6BA	1"	300	2.36	7.95	4.88	2	0.98	0.06	3.50	0.75
6DA	1"	600	2.60	8.19	4.88	2	0.98	0.25	3.50	0.75

- 1) Finishing: UNI - Ra 12,5 µm max;
DIN - Rz 40...160 µm; ASME - AARH 125...250 µin
- 2) Available also DN 20,32,40,50 e 1" 1/2 , 2"
- 3) N°4 threaded or through holes.

Set- point adjustment

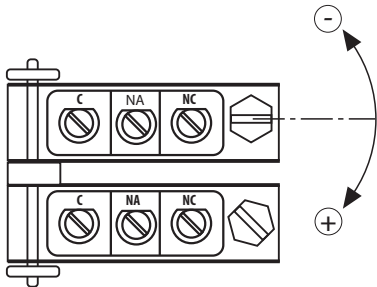

MICROSWITCHES

ohmic load

Single / Double	Type	250	125	24
		Vac	Vac	Vdc
C/D	std.	15A	15A	0,1A
G/H	SPLASH	15A	15A	0,1A
I/L	goldplated		1A	0,1A
M/P	inert gas filled	15A	15A	0,1A
N/R	goldplated and inert gas filled		1A	0,1A
E	adjustable dead band	20A	20A	0,1A
S/T	SPLASH VDC	15A	15A	2A
U/V	inert gas filled VDC	15A	15A	2A

F1
1 - R 1/2-ISO 7/1
2 - R 3/4-ISO 7/1
3 - 1/2-14 NPT
4 - 3/4-14 NPT
A - M20 x 1,5

OPTIONS

F03 - Special overpressure stop	E30 - Nace MR 01.03 version (1)
M26 - PTFE diaphragm	M23 - Monel diaphragm
T01 - Tropicalization	M22 - Hastelloy C diaphragm
P02 - Oxygen service	M29 - Tantalum diaphragm

(1) Monel or Hastelloy C diaphragm.

"HOW TO ORDER" SEQUENCE

Section / Model / Set-point Adjustment / Microswitch / Electrical connection / Process connection / ATEX / Options
3 42 C, D, G, H 1 OOO...QSO 2D2 F03...M29
I, L, M, P 2 4AA....6AA
N, R, E 3
S, T, U, V 4
A

diaphragm pressure switches ATEX flameproof enclosure



II 2 GD Ex db IIC T6 Ex tb IIC T85°C

Certificate :
0425 ATEX 2634

These flameproof electrical apparatus comply with European Directive ATEX 2014/34/EU, for group II and category 2 GD. They are suitable for a variety of uses in hazardous zones 1, 2, 21 and 22 in which the use of flameproof instrument is required. The sensing element is a metallic diaphragm and acts directly on the microswitch through a self-centering pivot. The simplicity of the design, without levers, cams or similar mechanisms, gives the unit an exceptionally long working life.

3.43 - Standard Model

Type of ignition protection as per EN 60079-0 and EN 60079-1:
Ex db IIC T6 Ex tb IIC T85°C.

Protection: IP 65 as per EN 60529.

Ranges: 0...1 bar/0...160 bar; -1...0 bar.

Electrical specifications: N. 1...2 SPDT microswitches, or N.1 with adjustable differential (see microswitches table).

Differential: fixed, or adjustable 10%...50% of setting range (see microswitches table).

Repeatability: ≤ 1% of the full setting value.

Set-point adjustment: internal, micrometric adjustable.

Earth contacts: N. 1 internal, N. 1 external.

Process fluid temperature: -4...+140°F (-20...+60 °C).

Ambient temperature: -4...+149°F (-20...+65 °C).

Thermal drift: ≤ 0,027% / °F (≤ 0,05% / °C).

Process connection: AISI 316 st.st.

Elastic element: AISI 316 st.st. diaphragm for pressure ranges ≤ 2,5 bar; carbon steel diaphragm covered with AISI 316 st.st. for pressure ranges > 2,5 bar. Diaphragm PTFE gasket.

Case: aluminium, blue polyurethane painted.

Cover: aluminium, beige polyurethane painted.

Tag: AISI 304 st.st., etched.

Tell-tale vents: polypropylene.

Setting ranges	Test pressure	Special overrange (cod. F03)	Differential 1 micro (2)	Differential 2 micro (2)
0,06...1 bar (1)	1,2 bar	10 bar	25 mbar	60 mbar
0,06...1,6 bar (1)	2 bar	10 bar	30 mbar	60 mbar
0,06...2,5 bar (1)	3 bar	10 bar	40 mbar	60 mbar
0,08...4 bar	5 bar	15 bar	50 mbar	80 mbar
0,09...6 bar	8 bar	15 bar	60 mbar	90 mbar
0,15...10 bar	12 bar	20 bar	100 mbar	150 mbar
0,25...16 bar	20 bar	30 bar	160 mbar	250 mbar
0,4...25 bar	30 bar	35 bar	250 mbar	400 mbar
0,6...40 bar	48 bar	60 bar	400 mbar	600 mbar
0,9...60 bar	70 bar	80 bar	600 mbar	900 mbar
6...100 bar	120 bar		4 bar	6 bar
8...160 bar	185 bar		5 bar	8 bar

(1) also available for vacuum and compound

(2) differential and minimum set-point values for microswitches cod. I, L, N, R, S, T, U, V are 300% of those shown in table.

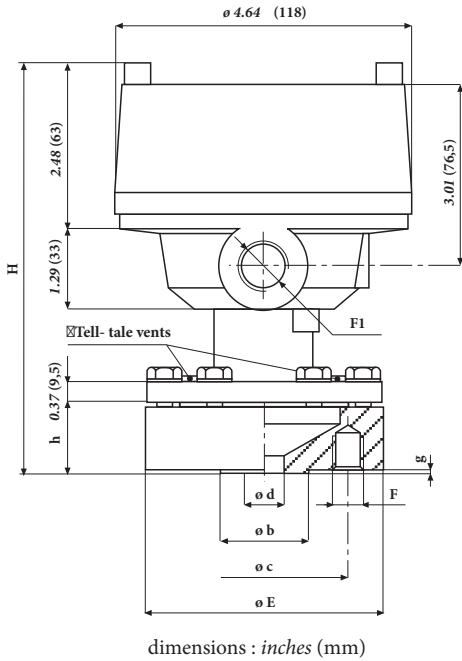

UNI - DIN STANDARDS (1)

dimensions : mm

Code	DN(2)	PN-bar	h	H	E	b	d	g	c	F	N (3)
SO0	40	6	27	169	130	80	40	3	100	M12	4
SQ0	40	10...16	27	169	150	88	40	3	110	M16	4
SS0	40	25...40	27	169	150	88	40	3	110	M16	4
TO0	50	6	27	169	140	90	50	3	110	M12	4
TQ0	50	10...16	27	169	165	102	50	3	125	M16	4
TS0	50	25...40	27	169	165	102	50	3	125	M16	4

ASME STANDARDS (1)

dimensions : inches

Code	DN(2)	Class	h	H	E	b	d	g	c	F	N(3)
AAA	1" 1/2	150	1.06	6.65	5	2.87	1.57	0.06	3.87	1/2" 13UNC	4
ABA	1" 1/2	300	1.06	6.65	6.12	2.87	1.57	0.06	4.50	3/4" 10UNC	4
ADA	1" 1/2	600	1.91	7.50	6.12	2.87	1.57	0.25	4.50	3/4" 10UNC	4
BAA	2"	150	1.06	6.65	6.12	3.63	1.97	0.06	4.75	5/8" 11UNC	4
BBA	2"	300	1.06	6.65	6.50	3.63	1.97	0.06	5	5/8" 11UNC	8
BDA	2"	600	1.91	7.50	6.50	3.63	1.97	0.25	5	5/8" 11UNC	8

- 1) Finishing: UNI - Ra 12,5 µm max; DIN - Rz 40...160 µm; ASME - AARH 125...250 µm
- 2) Also available DN 15,20,25 e 1/2 1".
- 3) N° of threaded or through holes.

Set-point adjustment

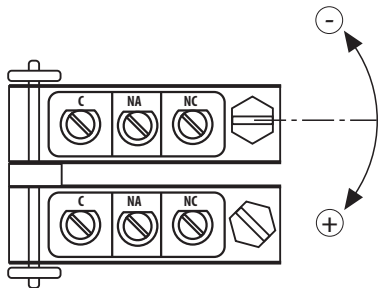

MICROSWITCHES
ohmic load

Single / Double	Type	250	125	24
		Vac	Vac	Vdc
C/D	std.	15A	15A	0,1A
G/H	SPLASH	15A	15A	0,1A
I/L	goldplated		1A	0,1A
M/P	inert gas filled	15A	15A	0,1A
N/R	goldplated and inert gas filled		1A	0,1A
E	adjustable dead band	20A	20A	0,1A
S/T	SPLASH VDC	15A	15A	2A
U/V	inert gas filled VDC	15A	15A	2A

F1
1 - R 1/2-ISO 7/1
2 - R 3/4-ISO 7/1
3 - 1/2-14 NPT
4 - 3/4-14 NPT
A - M20 x 1,5

OPTIONS

F03 - Special overpressure stop	E30 - Nace MR 01.03 version (1)
M26 - PTFE diaphragm	M23 - Monel diaphragm
T01 - Tropicalization	M22 - Hastelloy C diaphragm
P02 - Oxygen service	M29 - Tantalum diaphragm

(1) Monel or Hastelloy C diaphragm.

"HOW TO ORDER" SEQUENCE

Section / Model / Set-point Adjustment / Microswitch / Electrical connection / Process connection / ATEX / Options

3 43 C, D, G, H 1 SQ0...TS0 2D2 F03...M29
I, L, M, P 2 AAA...BDA
N, R, E 3
S, T, U, V 4
A

diaphragm pressure switches ATEX flameproof enclosure



II 2 GD Ex db IIC T6 Ex tb IIIC T85°C

Certificate:
0425 ATEX 2634

These flameproof electrical apparatus comply with European Directive ATEX 2014/34/EU, for group II and category 2 GD. They are suitable for a variety of uses in hazardous zones 1, 2, 21 and 22 in which the use of flameproof instrument is required. The sensing element is a metallic diaphragm and acts directly on the microswitch through a self-centering pivot. The simplicity of the design, without levers, cams or similar mechanisms, gives the unit an exceptionally long working life.

3.45 - Standard Model

Type of ignition protection as per EN 60079-0 and EN 60079-1:
Ex db IIC T6 Ex tb IIIC T85°C.

Protection: IP 65 as per EN 60529.

Ranges: 0...40 mbar/0...600mbar; -40...0 mbar/-600...0 mbar.

Electrical specifications: N. 1...2 SPDT microswitches (see microswitches table).

Differential: fixed.

Repeatability: ≤ 1% of the full setting value.

Set-point adjustment: internal, micrometric adjustable.

Earth contacts: N. 1 internal, N. 1 external.

Process fluid temperature: -4...+140°F (-20...+60 °C).

Ambient temperature: -4...+149°F (-20...+65 °C).

Thermal drift: ≤ 0,027% / °F (≤ 0,05% / °C).

Process connection: AISI 316L st.st.

Elastic element: AISI 316 Ti st.st. diaphragm. PTFE gasket.

Case: aluminium, blue polyurethane painted.

Cover: aluminium, beige polyurethane painted.

Tag: AISI 304 st.st., etched.

Tell-tale vents: polypropylene.

Setting ranges (1)	Test pressure	Differential 1 micro (2)	Differential 2 micro (2)
5...40 mbar	0,5 bar	4 mbar	5 mbar
5...60 mbar	0,5 bar	4 mbar	5 mbar
6...100 mbar	0,5 bar	4 mbar	6 mbar
9...160 mbar	0,5 bar	6 mbar	9 mbar
9...250 mbar	1 bar	6 mbar	9 mbar
15...400 mbar	1 bar	10 mbar	15 mbar
18...600 mbar	1 bar	12 mbar	18 mbar

(1) also available for vacuum and compound

(2) differential and minimum set-point values for microswitches cod. I, L, N, R, S, T, U, V are 300% of those shown in table.

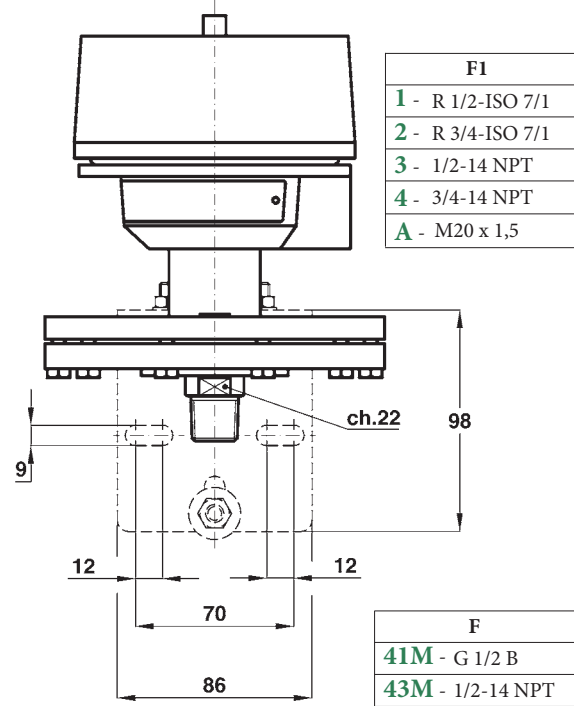
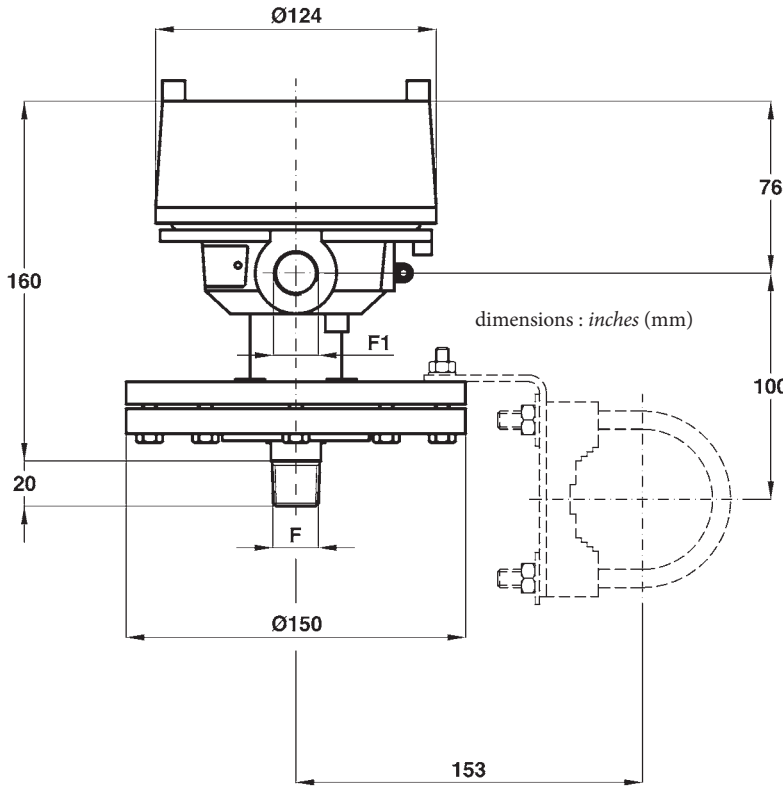

Set- point adjustment

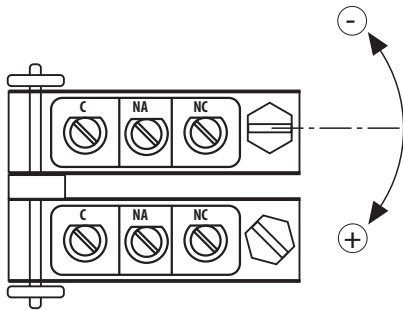

MICROSWITCHES
ohmic load

Simple / Doble	Type	250	125	24
		Vac	Vac	Vdc
C/D	std.	15A	15A	0,1A
G/H	SPLASH	15A	15A	0,1A
I/L	goldplated		1A	0,1A
M/P	inert gas filled	15A	15A	0,1A
N/R	goldplated and inert gas filled		1A	0,1A
S/T	SPLASH VDC	15A	15A	2A
U/V	inert gas filled VDC	15A	15A	2A

OPTIONS

M26 - PTFE diaphragm	M29 - Tantalum diaphragm
S16 - Wall mounting bracket	S31 - 2" stake's mounting bracket
T01 - Tropicalization	

(1) Monel or Hastelloy C diaphragm.

"HOW TO ORDER" SEQUENCE

Section / Model / Set-point Adjustment / Microswitch/ Electrical connection / Process connection / ATEX / Options

3 45 C, D, G, H 1 41M 2D2 M26...S31
 I, L, M, P 2 43M
 N, R, E 3 53M
 S, T, U, V 4 97M
 A

differential pressure switches ATEX flameproof enclosure



Certificate:
V



II 2 GD Ex db IIC T6 Ex tb IIIC T85°C

PED 2014/68/EU

These flameproof electrical apparatus comply with European Directive ATEX 2014/34/EU, for group II and category 2 GD. They are suitable for a variety of uses in hazardous zones 1, 2, 21 and 22 in which the use of flameproof instrument is required. The sensing element is a metallic diaphragm with 2 metallic bellows and acts directly on the microswitch through a self-centering pivot. The simplicity of the design, without levers, cams or similar mechanisms, gives the unit an exceptionally long working life.

3.48 - Standard Model

Type of ignition protection as per EN 60079-0 and EN 60079-1:
Ex db IIC T6 Ex tb IIIC T85°C.

Protection: IP 65 as per IEC 529.

Certificate: no. 04 ATEX 027, issued by CESI - Milano, notified body no. 0722.

Ranges: 0...1 bar/0...10 bar.

Electrical specifications: N. 1...2 SPDT microswitches, or N. 1 with adjustable differential (see microswitches table).

Differential: fixed, or adjustable 10%...50% of setting range (see microswitches table).

Repeatability: ≤ 1% of the full setting value.

Set-point adjustment: internal, micrometric adjustable.

Earth contacts: N. 1 internal, N. 1 external.

Process fluid temperature: -4...+140°F (-20...+60 °C).

Ambient temperature: -4...+149°F (-20...+65 °C).

Thermal drift: ≤ 0,027% / °F (≤ 0,05% / °C).

Process connection: AISI 316 st.st.

Elastic element: AISI 316 st.st. diaphragm with N. 2 AISI 321 st.st. bellows; PTFE gasket.

Case: aluminium, blue polyurethane painted.

Cover: aluminium, beige polyurethane painted.

Tag: AISI 304 st.st., silk-screen painted.

Tell-tale vents: polypropylene.

Flushing plugs: AISI 316 st.st.

Weight: 9.25 lbs (4,2 kg).

Setting ranges	One side	Both side	Differential	Differential
	static pressure	static pressure	1 micro (1)	2 micro (1)
0,1...1 bar	10 bar	25 bar	60 mbar	80 mbar
0,1...2,5 bar	15 bar	25 bar	60 mbar	80 mbar
0,2...4 bar	15 bar	25 bar	70 mbar	100 mbar
0,2...6 bar	15 bar	25 bar	100 mbar	150 mbar
0,2...10 bar	15 bar	25 bar	120 mbar	170 mbar

1) differential and minimum set-point values for microswitches cod. I, L, N, R, S, T, U, V are 300% of those shown in table.

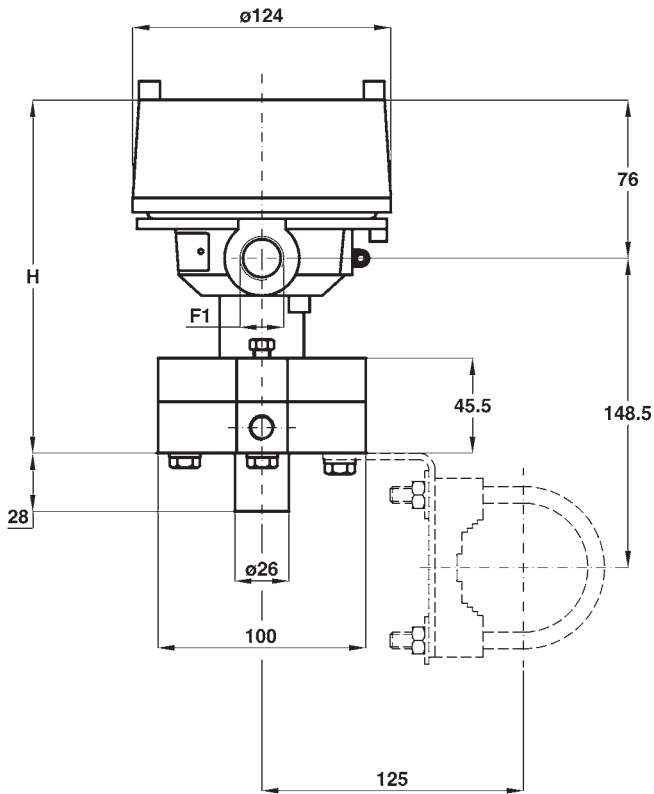

dimensions : inches (mm)

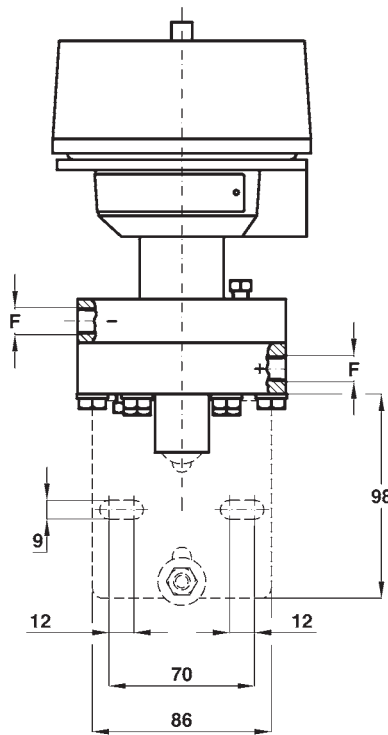

F1	
1	R 1/2-ISO 7/1
2	R 3/4-ISO 7/1
3	1/2-14 NPT
4	3/4-14 NPT
A	M20 x 1,5

F	
21F	G 1/4
23F	1/4-18 NPT
43F	1/2-14 NPT
43M	1/2-14 NPT M

Set- point adjustment

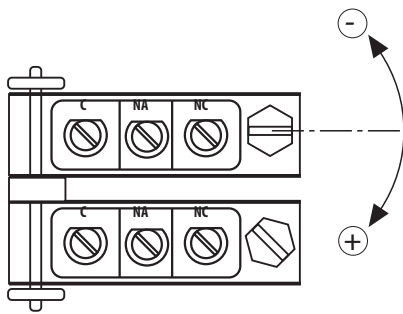

MICROSWITCHES
ohmic load

Single / Double	Type	250 Vac	125 Vac	24 Vdc
C/D	std.	15A	15A	0,1A
G/H	SPLASH	15A	15A	0,1A
I/L	goldplated		1A	0,1A
M/P	inert gas filled	15A	15A	0,1A
N/R	goldplated and inert gas filled		1A	0,1A
E	adjustable dead band	20A	20A	0,1A
S/T	SPLASH VDC	15A	15A	2A
U/V	inert gas filled VDC	15A	15A	2A

"HOW TO ORDER" SEQUENCE

Section / Model / Set-point Adjustment / Microswitch / Electrical connection / Process connection / ATEX / Options					
3 48	C, D, G, H	1	21F	2D2	
	I, L, M, P	2	23F		
	N, R, E	3	43F		
	S, T, U, V	4	43M		
		A			



differential pressure switches ATEX flameproof enclosure



**Certificate :
0425 ATEX 2634**



PED 2014/68/EU



II 2 GD Ex db IIC T6 Ex tb IIIC T85°C

These flameproof electrical apparatus comply with European Directive ATEX 2014/34/EU, for group II and category 2 GD. They are suitable for a variety of uses in hazardous zones 1, 2, 21 and 22 in which the use of flameproof instrument is required. The sensing element is a metallic diaphragm with 2 metallic bellows and acts directly on the microswitch through a self-centering pivot. The simplicity of the design, without levers, cams or similar mechanisms, gives the unit an exceptionally long working life.

3.49 - Standard Model

Type of ignition protection as per EN 60079-0 and EN 60079-1:
Ex db IIC T6 Ex tb IIIC T85°C.

Protection: IP 65 as per IEC 529.

Ranges: 0...250 mbar/0...600 mbar.

Electrical specifications: N. 1...2 SPDT microswitches, or N. 1 with adjustable differential. (see microswitches table)

Differential: fixed.

Repeatability: ≤ 1% of the full setting value.

Set-point adjustment: internal, micrometric adjustable.

Earth contacts: N. 1 internal, N. 1 external.

Process fluid temperature: -4...+140°F (-20...+60 °C).

Ambient temperature: -4...+149°F (-20...+65 °C).

Thermal drift: ≤ 0,027% / °F (≤ 0,05% / °C).

Process connection: AISI 316 st.st.

Elastic element: AISI 316 st.st. diaphragm with N. 2 AISI 321 st.st. bellows; PTFE gasket.

Case: aluminium, blue polyurethane painted.

Cover: aluminium, beige polyurethane painted.

Tag: AISI 304 st.st., silk-screen painted.

Tell-tale vents: polypropylene.

Flushing plugs: AISI 316 st.st.

Weight: 14.77 lbs (6,7 kg).

Setting ranges	One side static pressure	Both side static pressure	Differential 1 micro (1)	Differential 2 micro (1)
20...250 mbar	2,5 bar	4 bar	10 mbar	15 mbar
25...400 mbar	4 bar	4 bar	16 mbar	20 mbar
35...600 mbar	4 bar	4 bar	20 mbar	30 mbar

(1) differential and minimum set-point values for microswitches cod. I, L, N, R, S, T, U, V are 300% of those shown in table.

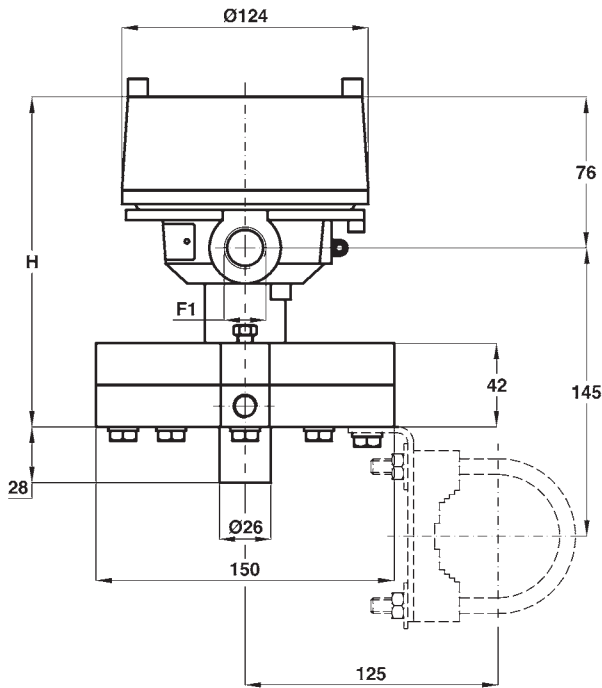

dimensions : inches (mm)

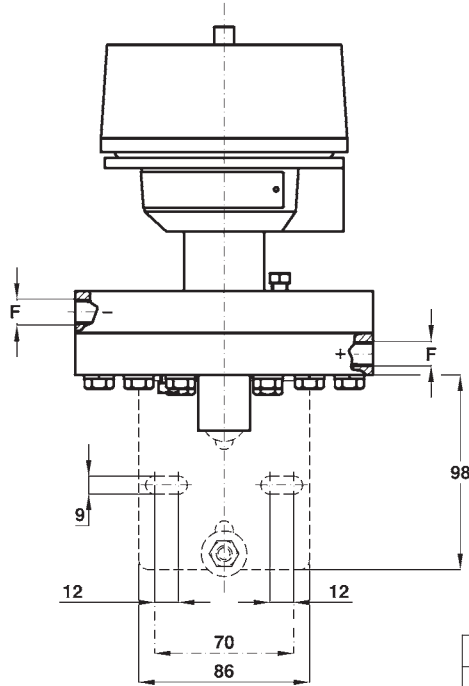

F1	
1	R 1/2-ISO 7/1
2	R 3/4-ISO 7/1
3	1/2-14 NPT
4	3/4-14 NPT
A	M20 x 1,5

F	
21F	G 1/4
23F	1/4-18 NPT
43F	1/2-14 NPT
43M	1/2-14 NPT M

Set- point adjustment

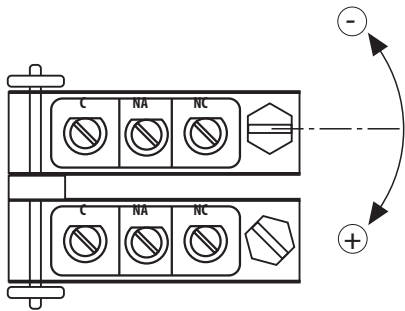

MICROSWITCHES
ohmic load

Single / Double	Type	250	125	24
		Vac	Vac	Vdc
C/D	std.	15A	15A	0,1A
G/H	SPLASH	15A	15A	0,1A
I/L	goldplated		1A	0,1A
M/P	inert gas filled	15A	15A	0,1A
N/R	goldplated and inert gas filled		1A	0,1A
S/T	SPLASH VDC	15A	15A	2A
U/V	inert gas filled VDC	15A	15A	2A

”HOW TO ORDER” SEQUENCE

Section / Model / Set-point Adjustment / Microswitch / Electrical connection / Process connection / ATEX / Options

3 49 C, D, G, H 1 21F 2D2
I, L, M, P 2 23F
N, R 3 43F
S, T, U, V 4 43M
A

NUOVA FIMA

NUOVA FIMA S.r.l.

P.O. BOX 58 Via Cesare Battisti, 59

28045 Inverio (NO) Italy

Tel. +39 0322.253200

Fax +39 0322.253232

info@nuovafima.com

www.nuovafima.com