

MEASURING INSTRUMENTS - STRUMENTI PER MISURARE

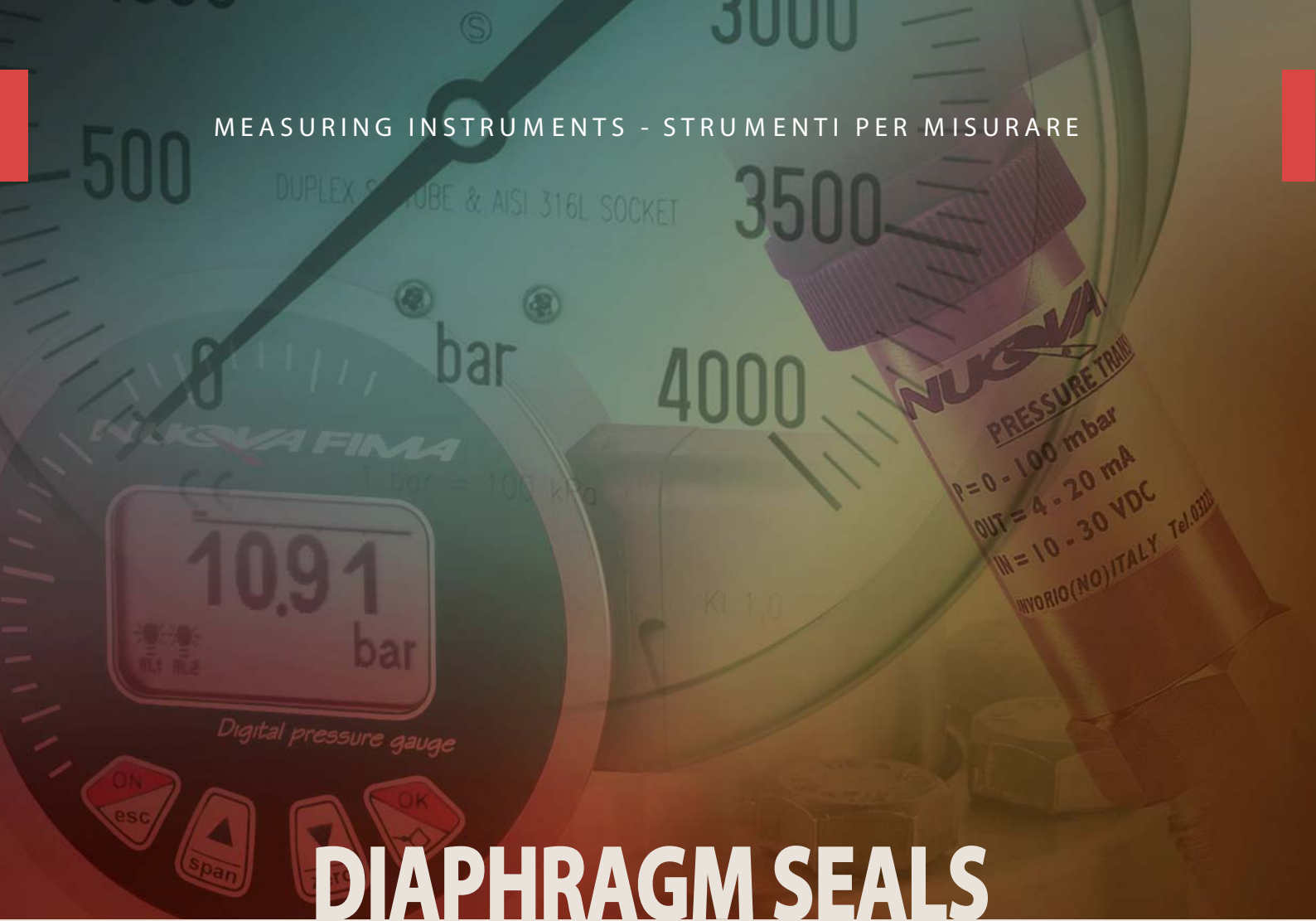

DIAPHRAGM SEALS

NUOVA FIMA

introduction to diaphragm seals



The diaphragm seal is designed to measure the process fluid pressure when the process fluid temperature is non-compatible to the instrument sensing element; when the process fluid may corrode the inner parts of the measuring instrument in contact with the fluid; when the fluid is highly viscous or it contains solid suspensions; when it solidifies at temperature changes. It is also used for long-distance pressure fluid transmission and measurement allowing to isolate dangerous fluids from the operating areas. It can be directly connected to the indicating instrument or through a capillary.

OPERATING PRINCIPLE

The diaphragm seal operating principle is based on the fluids non-compressibility (see drawing at right). The separation from the process fluid is obtained from an elastic diaphragm sealed to the diaphragm seal body. The inner chamber between the diaphragm and the Bourdon tube is at first evacuated than filled with properly degased fill-fluid. At this point the system is able to transmit the mechanical stress produced by the process fluid on the diaphragm to the Bourdon tube. Any air bubble in the circuit must be avoided as it could affect the right system operation.

RECOMMENDATIONS

The diaphragm and the body are in contact with the process fluid, therefore they must withstand the temperature and the possible fluid chemical aggression. A guide to the choice of the materials to use depending on the process medium is available under section "CORROSION/MATERIALS".

The filling fluid must be selected depending on the pressure fluid nature and temperature as well since any diaphragm fail may contaminate the process fluid and damage the whole process plant. A guide for a filling-fluid selection is available under section "FILLING FLUID".

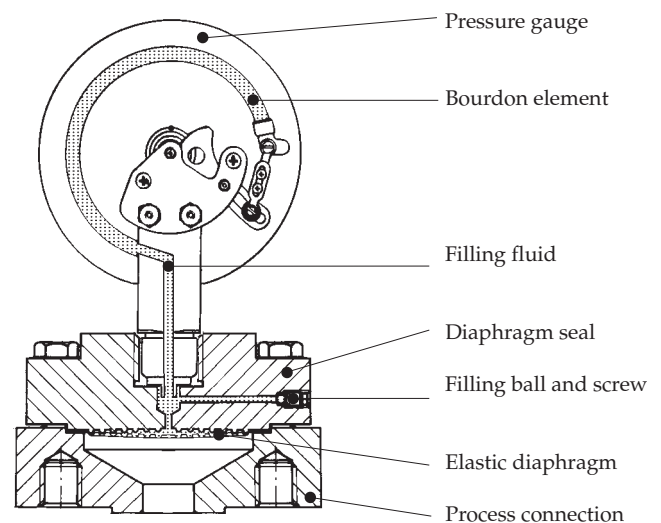

FUNCTIONAL CHARACTERISTICS

Accuracy: at 20 C $\pm 0,5...1\%$, depending on the diaphragm seal type. This accuracy value must be added to the pressure gauge accuracy.

Process fluid temperature: minimum -45 C, maximum 340 C, depending on the filling fluid, on the diaphragm material and on the process connection. For temperature higher than the indicated limits please contact the Technical Service Department.

TEMPERATURE INFLUENCE

The complete seal system composed by the diaphragm seal (with or without capillary) and the measuring instrument, is filled with a fixed amount of liquid at a fixed room temperature (generally +20 C ±2 C), called temperature of reference. Any ambient or fluid process temperature change produces a proportional variation of the filling fluid volume causing an inner pressure change that makes a zero off at the indicating instrument. In order to minimize such an error it is necessary to compensate the volume modified by temperature variations.

Diaphragm of small diameter can compensate only little volume changes (see Fig.1). It is recommended to use, in line with process requirements, diaphragm seals with large size diameter. In order to prevent the effects of temperature conduction between the diaphragm seal and the instrument, when the process temperature exceeds 100 C, it is required to fit the instrument with:

- Cooling element
- Capillary mounting

COOLING TOWER

The purpose of the cooling element is to protect the instrument from high temperatures. It reduces the filling fluid temperature inside the instrument to approximately the room temperature. The cooling element is recommended for instruments direct mounting when the process temperature is exceeding +100 C but is not higher than +250 C.

When a diaphragm seal provided with cooling element is installed on an insulated pipe, it is fundamental that the insulating coat is not covering the element radiant surface in order to assure the system proper working.

REMOTE MOUNTING (with capillary)

The capillary allows the instrument reading when it is far from the process connection. The capillary avoids the fluid process temperature effect on the instrument accuracy.

A 500mm capillary is generally long enough to reduce the indicating instrument temperature to the ambient temperature.

The capillary length must be as short as possible and it should not exceed 6mt because any ambient temperature variation could affect the instrument accuracy and response time (see fig.2).

The remote mounting requires instruments for wall or panel mounting.

If the level difference is known, it must be indicated in order. If not a field adjustment of the micromatic pointer in order to compensate the effect of extreme temperature variation, will be necessary.

Tab. 1 - FILLING LIQUIDS

Liquid type	Limits of process temperature
Silicone oil type "A"	-45 ... +150 C
Silicone oil type "B"	-20 ... +250 C
Silicone oil type "C"	+20 ... +340 C
"Fluorolube"	-60 ... +150 C
Food oil	-20 ... + 200 C

Glycerine or silicone should not be used with highly oxidizing agents such as oxygen, chlorine, nitric acid or hydrogen peroxide, because of spontaneous chemical reaction, inflammability or explosion. The use of fluorinates fluid is recommended in these cases.

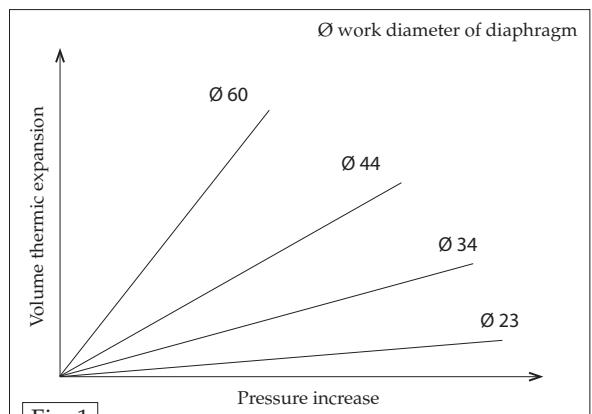

Fig. 1

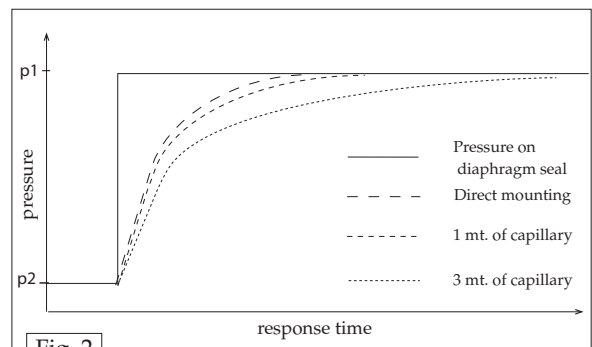

Fig. 2

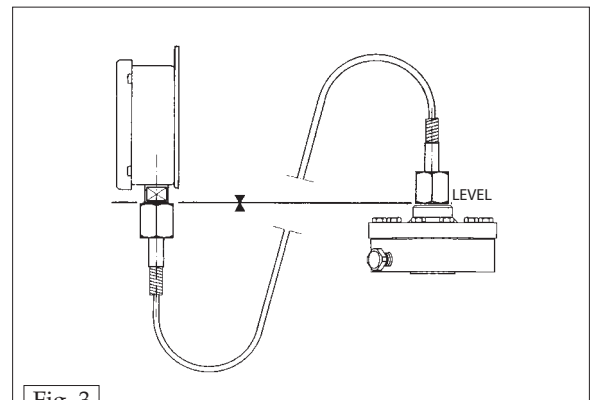

Fig. 3

Tab.2 - DIAPHRAGM SEAL CHOICE

An improper use of the instrument may be dangerous to the diaphragm seal, may cause failure and potential injury to the staff and plant.

Caution: all diaphragm seals must be chosen considering the process fluid and the working conditions in order to prevent inaccurate installations.

For material choice please see recommendations quoted on sheet 5...8.

For process fluids not listed in our guide (the material's life depends on temperature and process fluid concentration as well as for other working conditions) please contact our Technical Department.

In case of incomplete knowledge of the process fluid behaviour, it is suggested to install the diaphragm seal with a solid front pressure gauge.

In case of tube failure this instrument prevents that dangerous process fluid may hit the workers.

Type MGS9	∅ diaphragm (inches - mm)	Facing diaphragm	Welded diaphragm	Thread connection	Flanged connection
1B0	73,5		F	F	
1BS	44			F	
1A0-1AS	44			F	
111	38		F	F	
6W	63		F	F	F
MINI/A	34		F	F	
MINI/B	57		F	F	
2B	63		F	F	
SA	23,5 ... 44	F	F	F	
AL	34 ... 63	F	F		F
R	38	F	F		F
367	23,5	F	F	F	
3A	44				F
3B	73,5		F		F
6	73,5		F		F
5	38...63	F	F		F
4	34...57		F [1]		F
WAF	50...65	F	F		F
P	34...57			F	

[1] Not welded when PTFE coated

DIAPHRAGM SEAL INSTALLATION

The whole system (the pressure gauges with their diaphragm seal) must be kept packaged until installation time in order to protect all the components. Particular care must be taken to prevent damages to the diaphragm during installation of the system on the process. Scratches on the diaphragm surface are the starting point for chemical corrosion action while crush of concentric waves of the diaphragm surface may compromise the system operation.

The capillary and its welded joints to the body must not be bended or twisted. Capillary must not be used as handle for transportation of the system. Bends or extreme bending radius of capillary may cause throttling of the inner hole, may increase the response time or cause capillary breaking compromising the regular instrument operation. The capillary may bend with a minimum of 150mm. bending radius.

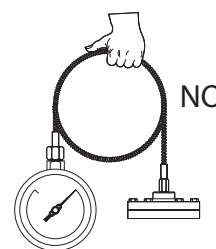

Extreme care must be taken to the sealing gasket mounting between diaphragm seal and process side to cover the diaphragm preventing damages or process fluid leakage.

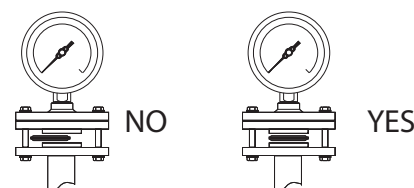

On models with threaded process connection, the mounting must be made through the key flat of the diaphragm seal body and not through the pressure range key flat: this may cause disassemble of the gauge/diaphragm system with eventually leakage of filling fluid.

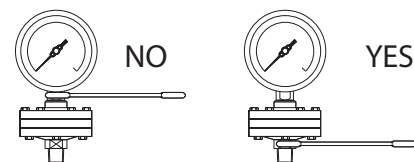

DIAPHRAGM SEAL FASTENING

All diaphragm seals are coupled and fastened to the instruments (except 63mm.) through a label seal. The tampering of the label seal or of the diaphragm seal/instrument coupling compromises their operation and warranty.

DO NOT REMOVE

<p style="text-align: center; font-size: small;">DIAPHRAGM MATERIAL</p> <input type="checkbox"/> AISI 316 L <input type="checkbox"/> HASTELLOY B <input type="checkbox"/> HASTELLOY C	<p style="text-align: center; font-size: small;">MONEL</p> <input type="checkbox"/> MONEL <input type="checkbox"/> PTFE <input type="checkbox"/> TANTALUM	<p style="text-align: center; font-size: small;">FILLING</p> <input type="checkbox"/> SILICON OIL <input type="checkbox"/> FOOD OIL <input type="checkbox"/> FLUOROLUBE
<p style="font-size: small;">A B C</p> <input type="checkbox"/> <input type="checkbox"/> <input type="checkbox"/>		

USE OF THE DIAPHRAGM SEAL

The working temperature must not exceed the limit of the material in use.

Working pressure: the maximum working pressure must be 75 % of the range of the instrument coupled with the diaphragm seal. For flanged diaphragm seal the maximum working pressure must also be within the flange rating pressure. The maximum admitted pressure on the diaphragm seal decreases when the temperature increases. To this subject please see table 5 where the connection between pressure/temperature for flange made with different materials are listed.

Temperature: the working temperature must be that of the instrument calibration and must be compatible with the chosen materials. For temperature exceeding 100 C diaphragm seals with capillary or with cooling system are recommended.

Oxygen and other oxidizing agents: glycerine and silicone should not be used with highly oxidizing agents such as oxygen, chlorine, nitric acid or hydrogen peroxide because of danger of spontaneous chemical reactions, inflammability or explosion. In these cases the use of fluorinates is recommended.(see tab.1)

MAINTENANCE

Periodically it may be necessary to remove sediments from the diaphragm and to check the corrosion or wear conditions of the entire system. This operation must be carried out by specially trained staff. The diaphragm seal and its pressure gauge must be removed from process and inspected than the diaphragm must be cleaned without using any tool that could damage it but with a solvent properly chosen according to the sediment to be removed.

Tab.3 - Material available C=Connection M=Diaphragm seal

Type MGS9	C.st.	AISI 316 st.st.	C.st. + PTFE	AISI 316 st.st. + PTFE	AISI 316 L st.st.	Monel 400	Hast. C276	Hast. B2	Titanium	Nickel	Tantalium	Incolloy 825	Inconel 600
1B0				C	CM	CM	CM				M	M	M
1BS	C			CM	CM		M (1)		M		M (1)		
1A0-1AS		C			CM	M	M						
111		C			M	M	M						
6W		C			CM	CM	CM	CM			M		
MINI/A-B		C			M								
2B					CM	CM	CM				M	M	M
SA-AL-367		C			M								
R		C			CM		M						
3A		C			CM	M	M	M	M		M		
6		C		CM	CM	M	M		M		M		
3B		C		CM	CM	M	M		M		M		
5		C			CM	CM	CM				CM		
4		C		CM	CM	CM	CM	CM	CM	CM	CM	M	M
WAF		C		C	M		CM	M			M		
P	C		M										

(1) PTFE coating

Tab.4 - Ranges available

Type (1)	-1...0	0...1	0...1,6	0...2,5	0...4	0...6	0...10	0...16	0...25	0...40	0...60	0...100	0...160	0...250	0...400	0...600
1B0-1BS	F	F	F	F	F	F	F	F	F	F	F	F	F	F	F	F
1A0											F	F	F	F	F	F
1AS															F	F
111						F	F	F	F	F	F	F	F	F	F	F
6W	F	F	F	F	F	F	F	F	F	F	F	F	F	F	F	F
MINI/A					F (2)	F (2)	F (2)	F	F	F	F	F	F	F	F	F
MINI/B	F	F	F	F	F	F	F	F	F	F	F	F	F	F	F	F
2B	F	F	F	F	F	F	F	F	F	F	F	F	F	F	F	F
SA DN25					F	F	F	F	F	F	F	F	F	F	F	F
SA 1" 1/2 - DN40					F	F	F	F	F	F	F	F	F	F	F	F
SA 2" - DN50			F	F	F	F	F	F	F	F	F	F	F	F	F	F
AL 1" 1/2					F	F	F	F	F	F	F	F	F	F	F	F
AL 2"			F	F	F	F	F	F	F	F	F	F	F	F	F	F
AL 2" 1/2		F	F	F	F	F	F	F	F	F	F	F	F	F	F	F
R						F	F	F	F	F	F	F	F	F	F	F
367										F	F	F	F	F	F	F
3A											F	F	F	F	F	F
3B	F	F	F	F	F	F	F	F	F	F	F	F	F	F	F	F
6	F	F	F	F	F	F	F	F	F	F	F	F	F	F	F	F
5		F	F	F	F	F	F	F	F	F	F	F	F	F	F	F
4		F	F	F	F	F	F	F	F	F	F	F	F	F	F	F
WAF	F	F	F	F	F	F	F	F	F	F	F	F	F	F	F	F
P		F	F	F	F	F	F	F	F	F	F	F	F	F	F	F

(1) Ranges are indicated in bar and they are related to the DS of the instrument installed as well as the flange rating. For further information see the concerning catalogue sheet - (2) for DN63 only

PRESSURE/TEMPERATURE RATING
(in according to standard ANSI/ASME B16.5 - ISO 7005)

Tab. 5 - Class 150 (PN 290 psi - PN 20 bar)

Temperature		Pressure (psi)						
°F	°C	C.st.	AISI 304	AISI 316	AISI 316L	Monel	Hast. B	Hast. C
-20 100	-29÷38	285	275	275	230	230	290	290
200	93	260	230	235	195	200	260	260
300	149	230	205	215	175	190	230	230
400	204	200	190	195	160	185	200	200
500	260	170	170	170	145	170	170	170
600	316	140	140	140	140	140	140	140
650	343	125	125	125	125	125	125	125
700	371	110	110	110	110	110	110	110
750	399	95	95	95	95	95	95	95
800	427	80	80	80	80	80	80	80

Tab. 6 - Class 300 (PN 750 psi - PN 50 bar)

Temperature		Pressure (psi)						
°F	°C	C.st.	AISI 304	AISI 316	AISI 316L	Monel	Hast. B	Hast. C
-20 100	-29÷38	740	720	720	600	600	750	750
200	93	675	600	620	505	530	750	750
300	149	655	540	560	455	495	730	730
400	204	635	495	515	415	480	705	705
500	260	600	465	480	380	475	665	665
600	316	550	435	450	360	475	605	605
650	343	535	430	445	350	475	590	590
700	371	535	425	430	345	475	570	570
750	399	505	415	425	335	470	530	530
800	427	410	405	420	330	460	510	510

Tab. 7 - Class 600 (PN 1500 psi - PN 110 bar)

Temperature		Pressure (psi)						
°F	°C	C.st.	AISI 304	AISI 316	AISI 316L	Monel	Hast. B	Hast. C
-20 100	-29÷38	1480	1440	1440	1200	1200	1500	1500
200	93	1350	1200	1240	1015	1055	1500	1500
300	149	1315	1080	1120	910	990	1455	1455
400	204	1270	995	1025	825	955	1410	1410
500	260	1200	930	955	765	950	1330	1330
600	316	1095	875	900	720	950	1210	1210
650	343	1075	860	890	700	950	1175	1175
700	371	1065	850	870	685	950	1135	1135
750	399	1010	830	855	670	935	1065	1065
800	427	825	805	845	660	915	1015	1015

Tab. 8 - Class 900 (PN 2250 psi - PN 150 bar)

Temperature		Pressure (psi)						
°F	°C	C.st.	AISI 304	AISI 316	AISI 316L	Monel	Hast. B	Hast. C
-20 100	-29÷38	2220	2160	2160	1800	1800	2250	2250
200	93	2025	1800	1860	1520	1585	2250	2250
300	149	1970	1620	1680	1360	1485	2185	2185
400	204	1900	1490	1540	1240	1435	2115	2115
500	260	1795	1395	1435	1145	1435	1995	1995
600	316	1640	1310	1355	1080	1435	1815	1815
650	343	1610	1290	1330	1050	1435	1765	1765
700	371	1600	1275	1305	1030	1435	1705	1705
750	399	1510	1245	1280	1010	1405	1595	1595
800	427	1235	1210	1265	985	1375	1520	1520

Tab. 9 - Class 1500 (PN 3750 psi - PN 260 bar)

Temperature		Pressure (psi)						
°F	°C	C.st.	AISI 304	AISI 316	AISI 316L	Monel	Hast. B	Hast. C
-20 100	-29÷38	3705	3600	3600	3000	3000	3750	3750
200	93	3375	3000	3095	2530	2640	3750	3750
300	149	3280	2700	2795	2270	2470	3640	3640
400	204	3170	2485	2570	2065	2390	3530	3530
500	260	2995	2330	2390	1910	2375	3325	3325
600	316	2735	2185	2255	1800	2375	3025	3025
650	343	2685	2150	2220	1750	2375	2940	2940
700	371	2665	2125	2170	1715	2375	2840	2840
750	399	2520	2075	2135	1680	2340	2660	2660
800	427	2060	2015	2110	1645	2290	2540	2540

Tab. 10 - Class 2500 (PN 6250 psi - PN 420 bar)

Temperature		Pressure (psi)						
°F	°C	C.st.	AISI 304	AISI 316	AISI 316L	Monel	Hast. B	Hast. C
-20 100	-29÷38	6170	6000	6000	5000	5000	6250	6250
200	93	5625	5000	5160	4220	4400	6250	6250
300	149	5470	4500	4660	3780	4120	6070	6070
400	204	5280	4140	4280	3440	3980	5880	5880
500	260	4990	3880	3980	3180	3960	5540	5540
600	316	4560	3640	3760	3000	3960	5040	5040
650	343	4475	3580	3700	2920	3960	4905	4905
700	371	4440	3540	3620	2860	3960	4730	4730
750	399	4200	3460	3560	2800	3900	4430	4430
800	427	3430	3360	3520	2740	3820	4230	4230

Tab. 11 - CORROSION vs. MATERIAL

Corrosive Substance	Temp. °F	Temp. °C	Concentration	C.Steel	AlSI 304 st.st.	AlSI 316 st.st.	Bronze	Brass	Monel 400	Nickel	Hastelloy B	Hastelloy C	Tantalum	PVC	Halar	Teflon	VITON	Fluorolube
Acetic Acid	200	93,3	All	D	C	B	C	D	C	D	C	A	A	C	A	A	C	
Acetic Anhydride	175	79,4	All	D	D	B	D	D	C	C	B	A	A	D	A	A	C	
Acetone	100	37,8	All	B	B	B	A	A	A	A	A	A	A	D	A	A	C	
Acetylene, Dry	400	204,4	100	A	A	A	D	D	B	B	A	A	A	A	A	A	A	
Alcohols	212	100	All	B	B	A	A	A	A	A	A	A	A	A	A	A	A	
Alkali Cleaners	212	100	All	C	B	A	B	D	A	A	A	B	B	A	A	A	A	
Aluminium Chloride	212	100	All	D	D	D	D	D	D	D	A	B	A	A	A	A	A	
Aluminium Hydroxide	212	100	All	B	B	B	B	B	B	B	C	B	A	A	A	A	B	
Aluminium Sulphate	212	100	All	D	D	A	C	D	D	D	A	A	A	A	A	A	A	
Amil Acetate	250	121,1	All	B	B	A	A	A	A	A	A	A	A	D	C	A	C	
Ammonium Chloride	212	100	<40	D	D	C	C	D	B	B	B	A	A	A	A	A	A	
Ammonium, Dry	600	315,6	100	A	A	A	D	D	A	A	A	A	C	A	A	A	C	
Ammonium Hydroxide	212	100	All	B	B	B	D	D	D	D	B	B	D	A	A	A	B	
Ammonium Nitrate	212	100	All	D	C	B	D	D	D	D	C	B	A	A	A	A	C	
Ammonium Sulphate	212	100	<50	D	D	B	C	D	B	B	C	B	A	A	A	A	C	
Aniline	250	121,1	100	A	A	A	D	D	B	B	B	B	A	D	C	A	C	
Argon	300	148,9	100	A	A	A	A	A	A	A	A	A	A	A	A	A	A	
Asphalt	250	121,1		B	B	A	B	B	A	A	B	A	A	B	A	A	A	
Atmosphere, Ind. & Marine				B	A	A	A	B	A	A	A	A	A	A	A	A	A	
Atmosphere, Rural				B	A	A	A	A	A	A	A	A	A	A	A	A	A	
Bauxite & Water	212	100	All	B	B	A	B	B	B	B	B	B	A	A	A	A	A	
Benzene	212	100	All	B	B	B	A	B	A	A	B	B	A	C	C	A	B	
Benzidine				B	B	B	B	B	B	B	B	B	A	C	A	A	B	
Benzoic Acid				D	D	B	C	C	B	B	A	A	A	A	A	A	A	
Bier	70	21,1		C	C	A	A	B	A	A	A	A	A	A	A	A	A	
Borax (sodium borate)	212	100	<50	B	B	C	A	A	A	A	A	B	A	A	A	A	A	
Boric Acid	212	100	All	D	D	B	B	B	B	B	A	A	A	A	A	A	A	
Bromine, Dry	125	51,7	100	D	D	D	D	D	A	A	A	A	A	D	A	A	A	
Bromobenzene	212	100	100	C	B	B	B	B	B	B	B	B	A	C	B	A	B	
Butane	212	100		A	A	A	A	A	A	A	A	A	A	B	A	A	A	
Butyl Alcohol	212	100		B	A	A	A	A	A	A	A	A	A	B	A	A	A	
Butyric Acid	212	100	All	D	C	B	C	D	B	C	B	A	A	C	A	A	C	
Calcium Bisulphite	212	100	All	D	C	B	D	D	D	D	D	C	A	A	A	A	A	
Calcium Chloride	212	100	All	C	C	C	B	C	B	A	B	A	A	A	A	A	A	
Calcium Hydroxide	212	100	10	B	B	B	B	B	B	B	B	A	C	A	A	A	A	
Calcium Hypochlorite	212	100	All	D	D	D	C	C	D	D	C	B	A	A	A	A	B	
Carbon Dioxide, Dry	100	37,8		A	A	A	A	A	A	A	A	A	A	A	A	A	A	
Carbon Sulphide	125	51,7		B	B	A	B	A	B	B	A	A	A	D	A	A	A	
Carbon Tetrachloride, Dry	212	100	100	C	A	A	A	C	A	A	D	B	A	D	C	A	A	
Carbon Tetrachloride, Moist	212	100		D	D	C	D	D	A	A	D	B	A	D	C	A	A	
Carbonated Water	212	100	All	D	A	B	B	D	C	C	A	A	A	A	A	A	A	
Carbonic Oxide	300	148,9		A	A	A	A	B	A	A	A	A	A	A	A	A	A	
Caustic Potassium	212	100	<50	D	B	B	D	D	A	A	B	C	D	A	A	A	C	
Caustic Soda	212	100	All	C	C	C	D	D	B	B	B	C	D	A	A	A	C	
Caustic Soda	212	100	<40	C	B	A	B	D	A	A	A	B	D	A	A	A	C	
Cement Slurry	212	100	All	B	A	A	B	B	B	B	B	B	C	A	A	A	C	
Chloride	500	260		B	A	A	D	D	B	C	B	A	A	A	A	A	C	
Chlorine Dioxide	150	65,6		D	D	D	D	D	D	D	B	B	A	D	B	A	B	
Chlorine, Dry	200	93,3	100	B	B	C	B	C	B	B	C	A	A	C	A	A	A	
Chlorine, Moist	200	93,3	All	D	D	D	D	D	D	D	D	A	A	C	A	A	A	
Chloroacetic Acid	212	100	All	D	D	D	D	D	C	C	B	A	A	C	A	A	C	
Chlorobenzene	150	65,6	100	C	B	B	B	C	B	B	B	B	A	D	B	A	A	
Choroform, Dry	150	65,6	100	A	B	C	B	B	A	A	B	B	A	C	B	A	A	
Chromic Acid	212	100	All	C	D	D	D	D	D	D	D	D	A	C	A	A	A	
Chromium Plating Solution	212	100	All	C	D	D	D	D	D	D	D	D	A	C	A	A	A	
Citric Acid	212	100	All	D	C	A	C	D	C	C	A	A	A	A	A	A	A	
Coffee	212	100	All	D	B	A	A	C	B	B	B	A	A	A	A	A	A	
Copper Chloride	212	100	All	D	D	D	C	D	D	D	D	D	A	A	A	A	A	
Copper Nitrate	212	100	All	D	B	B	D	D	D	D	D	D	A	A	A	A	A	
Copper Plating Solutions (Acid)	212	100	All	D	C	B	D	D	B	B	C	C	A	A	A	A	A	

A = Recommended Best service life Attack < 0,05 mm/year
 B = Suitable Good service life Attack 0,05...0,5 mm/year
 C = Not recommended Fair service life Attack 0,5...1,27 mm/year
 D = Unsuitable No service life Attack > 1,27 mm/year

This tab is a guide. The purchaser will directly choose the most suitable material for the process conditions. (The diaphragm thickness goes from 0,05 mm to 0,15mm according to the material and the diaphragm type chosen.) For further information please contact our Service Technical Department.

Tab. 11 - CORROSION/MATERIAL

Corrosive substance	Temp. °F	Temp. °C	Concentration	C.Steel	AISI 304 st.st.	AISI 316 st.st	Bronze	Brass	Monel 400	Nickel	Hastelloy B	Hastelloy C	Tantalium	PVC	Halar	Teflon	VITON	Fluorolube
Copper Plating Solutions (cyanide)	212	100	All	B	A	A	D	D	B	B	B	A	A	A	A	A	A	A
Copper Sulphate	212	100	<40	D	C	B	C	D	D	D	C	A	A	A	A	A	A	A
Corn Oil	500	260	All	D	B	A	A	C	B	B	A	A	A	A	A	A	A	A
Creosol	212	100	All	B	A	A	B	C	B	B	B	A	A	D	A	A	A	A
Creosote	212	100		B	B	B	B	C	B	B	B	A	A	D	A	A	A	A
Crude Oil	300	148,9	All	B	B	B	B	C	A	B	B	C	A	B	A	A	A	A
Ethanol	212	100	All	B	A	A	A	A	A	A	B	A	A	A	A	A	A	A
Ethyl Acetate	212	100	100	D	B	B	B	B	B	C	C	B	A	D	C	A	C	C
Ethyl Chloride, Dry	212	100		B	C	A	A	A	B	A	B	B	A	D	A	A	A	A
Ethylene Glycol	212	100	All	C	B	B	B	B	B	B	A	A	A	A	A	A	A	A
Ethylene Oxide	75	23,9	100	B	A	B	D	D	B	B	A	A	A	C	B	A	C	C
Fatty Acids	500	260	100	D	C	A	C	C	B	A	A	A	A	A	A	A	A	A
Ferric Chloride	150	65,6	<50	D	D	D	D	D	D	D	D	B	A	A	A	A	A	A
Ferric Sulphate	150	65,6	10	D	B	A	D	D	D	D	B	A	A	A	A	A	A	A
Ferrous Chloride	212	100	<50	D	D	D	C	D	D	D	B	B	A	A	A	A	A	A
Ferrous Sulphate	212	100	All	D	C	B	C	D	C	D	B	B	A	A	A	A	A	A
Fluorine, Gas	300	148,9	100	D	A	A	C	C	A	A	C	B	D	B	A	A	C	C
Fluorine, Liquid	75	23,9	100	D	A	A	B	C	A	A	C	B	C	B	B	A	C	C
Fluorosilicic Acid	75	23,9	10	D	B	B	C	C	A	B	B	A	C	A	A	A	A	B
Formaldehyde	212	100	<50	D	B	A	B	B	B	B	B	A	A	B	B	A	B	B
Formic Acid	212	100	All	D	B	D	B	C	B	B	A	A	A	B	A	A	A	A
Gasoline	200	93,3		A	A	A	A	A	C	A	A	A	A	B	A	A	A	A
Glucose	300	148,9	All	B	A	A	A	A	A	A	A	A	A	A	A	A	A	A
Glue	300	148,9	All	C	A	A	A	B	A	A	A	A	A	A	A	A	A	A
Glycerine	212	100	All	B	A	A	B	B	A	A	A	A	A	A	A	A	A	A
Hexane, Dry	212	100		A	A	A	A	A	A	A	A	A	A	A	A	A	A	A
Hydrobromic Acid	212	100	All	D	D	D	D	D	D	D	B	D	A	B	A	A	A	A
Hydrochloridric Acid	212	100	All	D	D	D	D	D	D	D	B	C	A	B	A	A	A	A
Hydrofluoric Acid	212	100	All	D	D	D	C	D	B	D	B	B	D	C	A	A	C	C
Hydrogen	500	260		B	A	A	A	A	A	A	A	A	A	A	A	A	A	A
Hydrogen Chloride	400	204,4		D	C	C	D	D	A	A	A	A	A	A	A	A	A	A
Hydrogen Fluoride, Dry	200	93,3	100	C	B	B	C	C	B	B	C	B	C	A	A	A	C	C
Hydrogen Peroxide	212	100	30	D	C	B	D	D	C	C	C	C	A	A	A	A	A	A
Hydrogen Peroxide	212	100	100	D	C	C	D	D	C	C	D	C	A	A	A	A	A	A
Kerosene	300	148,9		A	A	A	A	A	A	A	A	A	A	A	A	A	A	A
Lacquers & Thinners	200	93,3	All	B	A	A	A	B	A	A	A	A	A	D	C	A	C	C
Lactic Acid	212	100	All	D	C	B	D	D	D	D	B	B	A	A	C	A	A	A
Lime	212	100	All	B	B	B	B	B	B	B	B	A	A	A	A	A	A	A
Linseed Oil	75	23,9		A	A	A	B	C	B	B	B	B	A	A	A	A	A	A
Magnesium Chloride	212	100	<40	D	D	C	B	C	B	A	A	A	B	A	A	A	A	A
Magnesium Oxide	212	100	All	B	B	B	A	B	B	A	B	B	D	A	A	A	A	A
Magnesium Sulphate	212	100	<50	B	A	A	A	B	A	A	C	A	A	A	A	A	A	A
Mercuric Chloride	75	23,9	10	D	D	D	D	D	D	C	C	B	A	A	A	A	A	A
Mercury				A	A	A	D	D	C	B	B	B	A	A	A	A	A	A
Methyl Chloride, Dry	212	100	100	A	B	A	A	B	B	B	B	B	A	D	A	A	A	A
Methylene Chloride	212	100	100	C	C	C	C	B	B	C	A	A	A	D	C	A	B	B
Milk				D	A	A	B	C	C	A	B	B	A	A	A	A	A	A
Naphta	75	23,9	100	B	A	A	A	A	A	A	B	A	A	B	A	A	A	A
Naphtaline	212	100	100	A	A	A	B	B	B	B	B	B	A	C	A	A	A	A
Nickel Chloride	212	100	<40	D	D	C	D	D	B	C	A	B	A	A	A	A	A	A
Nickel Sulphate	212	100		D	C	B	B	C	B	B	B	B	A	A	A	A	A	A
Nitric Acid	75	23,9	All	D	A	A	D	D	D	D	D	D	B	A	A	A	A	A
Nitric Acid	212	100	All	D	C	C	D	D	D	D	D	D	A	C	B	A	C	C
Oxalic Acid	212	100	All	D	D	D	B	C	B	C	B	B	A	A	A	A	A	A
Oxygen	300	148,9	All	A	A	A	A	A	A	A	A	A	A	A	A	A	A	A
Perchloric Acid	120	48,9	All	D	D	D	D	D	D	D	C	D	A	D	A	A	A	A
Phenol	175	79,4	100	B	B	A	A	B	A	A	A	A	A	C	A	A	A	A
Phosphoric Acid	212	100	All	D	C	C	D	D	D	D	B	C	A	A	A	A	A	A
Phthalic Anhydride	250	121,1	100	B	A	A	C	C	A	A	B	A	A	C	B	A	B	B
Picric Acid	212	100	All	D	B	B	D	D	D	D	D	B	A	C	A	A	A	A

A = Recommended Best service life Attack < 0,05 mm/year
 B = Suitable Good service life Attack 0,05...0,5 mm/year
 C = Not recommended Fair service life Attack 0,5...1,27 mm/year
 D = Unsuitable No service life Attack > 1,27 mm/year

This tab is a guide. The purchaser will directly choose the most suitable material for the process conditions. (The diaphragm thickness goes from 0,05 mm to 0,15mm according to the material and the diaphragm type chosen.) For further information please contact our Service Technical Department.

Tab. 11 - CORROSION/MATERIALS

Corrosive substances	Temp. °F	Temp. °C	Concentrations	Carbon steel	AlSI 304 st.st.	AlSI 316 st.st.	Bronze	Brass	Monel 400	Nickel	Hastelloy B	Hastelloy C	Tantalum	PVC	Halar	Teflon	VITON	Fluorolube
Propan	300	148,9		A	A	A	A	A	A	A	A	A	A	A	A	A	A	A
Quinine	212	100	100	D	B	B	B	B	B	B	B	B	A	A	A	A	A	A
Resin Solution	150	65,6	All	D	B	A	B	B	B	B	B	A	A	D	A	A	C	
Rochelle Salt	212	100	100	D	B	B	B	C	B	B	B	B	A	A	A	A	A	A
Rosin	700	371,1	100	D	B	B	B	B	A	A	B	A	A	A	A	A	A	A
Sea Water	75	23,9		D	C	C	D	C	A	A	A	A	A	A	A	A	A	A
Silicate Solutions	212	100	All	B	A	A	B	B	A	A	A	A	A	A	A	A	A	A
Silicone Fluids	212	100	100	A	A	A	A	A	A	A	A	A	A	A	A	A	A	A
Silver Nitrate	212	100	<60	D	B	B	D	D	D	D	B	C	A	A	A	A	A	A
Soap & Detergents	212	100	All	B	A	A	A	B	A	A	A	A	A	A	A	A	A	A
Sodium Bicarbonate	212	100	20	B	A	A	B	B	A	A	B	B	A	A	A	A	A	A
Sodium Bisulphate	212	100	<10	D	B	B	B	D	B	B	B	B	A	A	A	A	A	A
Sodium Bisulphite	212	100	<40	D	D	C	C	C	B	C	C	B	A	A	A	A	A	A
Sodium Carbonate	212	100	<40	B	B	B	B	C	B	B	B	B	A	A	A	A	A	A
Sodium Chloride	212	100	<40	C	C	C	B	B	B	B	B	B	A	A	A	A	A	A
Sodium Cyanide	212	100	10	B	A	A	D	D	D	D	B	C	A	A	A	A	A	A
Sodium Hydroxide	180	82,2	<60	C	B	A	B	C	A	A	A	B	D	A	A	A	C	
Sodium Hypochlorite	75	23,9	10	D	D	D	D	D	D	D	C	A	A	A	A	A	A	A
Sodium Nitrate	212	100	<50	B	A	A	C	C	B	B	C	B	A	A	A	A	B	
Sodium Nitrate	212	100	60	B	C	B	B	B	B	B	B	B	A	A	A	A	B	
Sodium Peroxide	212	100	10	B	B	B	C	D	B	B	B	B	A	A	A	A	A	A
Sodium Phosphate (Tribasic)	212	100	All	B	A	A	B	B	B	B	A	B	A	A	A	A	A	A
Sodium Silicate	212	100	All	B	A	A	B	B	B	B	B	B	A	A	A	A	A	A
Sodium Sulphate	212	100	<50	B	B	B	B	B	B	B	B	B	A	A	A	A	A	A
Sodium Sulphate	212	100	10	D	A	A	C	D	B	B	C	B	A	A	A	A	A	A
Sodium Sulphide	175	79,4	20	D	A	A	D	D	B	B	B	B	D	A	A	A	A	A
Steam	800	426,7		A	A	A	D	D	B	B	B	B	A	C	A	A	B	
Sulphur Chloride, Dry	212	100	100	D	B	C	C	C	C	C	B	C	B	A	A	A	A	A
Sulphur Dioxide, Dry	500	260	100	B	B	B	C	D	B	B	B	B	A	A	A	A	C	
Sulphur Trioxide, Dry	300	148,9		B	B	B	C	C	B	B	A	B	D	A	A	A	A	A
Sulphuric Acid	212	100	10	D	D	D	D	D	D	D	C	B	A	A	A	A	A	A
Sulphuric Acid	212	100	<30	D	D	D	D	D	D	D	B	C	A	B	A	A	A	A
Sulphuric Acid	212	100	100	D	D	D	D	D	D	D	B	B	A	C	A	A	A	A
Sulphuric Acid, Fuming	175	79,4	100	D	A	B	D	D	D	D	B	B	C	C	A	A	B	
Sulphurous Acid	212	100	All	D	C	C	C	C	C	C	C	B	B	A	A	A	A	A
Tannic Acid	212	100	All	C	B	B	B	C	B	B	B	B	A	A	A	A	A	A
Tartaric Acid	212	100		D	A	A	B	C	B	B	B	B	A	A	A	A	A	A
Tin Chloride	125	51,7	All	D	D	D	D	D	D	D	B	B	A	A	A	A	A	A
Titanium Tetrachloride, Dry	75	23,9	100	A	B	B	D	D	B	B	B	B	A	A	A	A	A	A
Toluene	212	100		A	A	A	A	A	A	A	A	A	A	D	A	A	B	
Trichloroacetic Acid	212	100	All	D	D	D	D	D	B	C	B	B	A	D	C	A	C	
Trichloroethane, Dry	125	51,7		A	A	A	A	A	A	A	A	A	A	D	C	A	B	
Trichloroethylene, Dry	300	148,9		B	B	B	B	B	A	A	B	A	A	D	D	A	A	A
Turpentine	75	23,9	100	B	A	A	A	B	A	B	A	A	A	C	A	A	A	A
Urea	100	37,8	50	C	A	A	B	B	B	B	B	B	A	A	A	A	A	A
Varnish	250	121,1		A	A	A	B	B	A	A	A	A	A	D	A	A	A	A
Vynil Chloride	150	65,6	100	C	B	B	C	C	A	A	B	A	A	D	A	A	A	A
Water (demineralized)	212	100		C	A	A	A	B	A	A	A	A	A	A	A	A	A	A
Whiskey (hot mash)	212	100		C	A	A	B	B	A	B	A	A	A	B	A	A	A	A
Zinc Chloride	212	100	<40	D	D	D	C	D	B	B	B	B	A	A	A	A	A	A
Zinc Sulphate	212	100	<30	D	A	A	B	D	B	B	B	B	A	A	A	A	A	A

A = Recommended Best service life Attack < 0,05 mm/year
 B = Suitable Good service life Attack 0,05...0,5 mm/year
 C = Not recommended Fair service life Attack 0,5...1,27 mm/year
 D = Unsuitable No service life Attack > 1,27 mm/year

This tab is a guide. The purchaser will directly choose the most suitable material for the process conditions. (The diaphragm thickness goes from 0,05 mm to 0,15 mm according to the material and the diaphragm type chosen) For further information please contact our Service Technical Department.

(1) For this application Nuova Fima developed special diaphragm seals in special materials that have been subjected to a corrosion test.
 For further information please contact our Service Technical Department.



diaphragm seal with threaded connection



Diaphragm seals are designed to isolate the sensing element of pressure gauges, pressure switches and electronic pressure transmitter from process fluids which may be corrosive, viscous, sedimentous and/or with a high temperature. The diaphragm, welded for model 1B0 and mechanically clamped between the upper housing and intermediate ring for model 1BS, is leak proof tested to guarantee fill fluid separation from process fluid. This diaphragm seal can be cleaned by removing the lower housing. This construction feature and its compact design suits to many applications requiring frequent maintenance.

4.1B0 - MGS9/1B0 - without intermediate ring

Available ranges (see table below): *from 0...40 INWC to 0...580 psi* (from 0...0,1 to 0...40 bar).

Max working pressure: *0...870 psi* (60 bar) (3).

Process temperature: *-49...+302°F (-45°C...+150°C).*

Accuracy (1): (add to instrument accuracy) $\pm 0,5\%$ for direct mounting, $\pm 1\%$ for capillary mounting.

Instrument connection: AISI 304 st.st.

Diaphragm material:

4 - AISI 316L st.st.,

6 - Monel 400,

9 - Hastelloy C 276,

B - Tantalum,

J - Alloy 600,

I - Alloy 825;

U - 25.22.2.

Gaskets: PTFE up to *+482°F (+250°C)*; graphite over *+482°F (+250°C)*

Process connection:

5 - AISI 316L st.st.

N - AISI 316L st.st. PTFE coated (2),

6 - Monel 400

9 - Hastelloy C 276.

Clamp nuts and bolts: AISI 304 st.st.

Filling liquids: Silicon oil.

4.1BS - MGS9/1BS - with intermediate ring

Available ranges (see table below): *from -30...0 INHG to 0...580 psi* (from -1...0 to 0...40 bar).

Max working pressure: *0...870 psi* (60 bar) (3).

Process temperature: *-49...+302°F (-45°C...+150°C).*

Accuracy (1): (add to instrument accuracy) $\pm 0,5\%$ for direct mounting, $\pm 1\%$ for capillary mounting.

Instrument connection: AISI 304 st.st..

Diaphragm material:

4 - AISI 316L st.st.

8 - AISI 316L st.st. PTFE coated,(2)

E - Hastelloy C276 PTFE coated,(2)

C - Tantalum PTFE coated,(2)

2 - Titanium.

Gaskets: PTFE up to *+482°F (+250°C)*; graphite over *+482°F (+250°C)*

Process connection and intermediate ring:

5 - AISI 316L st.st.

N - AISI 316L st.st.,PTFE coated,(2)

F - Polipropylene,

V - PVC.

Clamp bolts: AISI 304 st.st.

Filling liquids: Silicon oil.

(1) at 68°F (20 °C) process temperature (or state temperature when ordering)

(2) Max temperature +302°F (+150°C), with PTFE coating - G 1/2 A only

(3) In case of order on demand of "continuous duty" model or in case of accidental overpressure, please see our catalogue MGS9/2B

Ranges

Instrument type	Minimum range	Maximum range	Notes
Bourdon tube, DS 4", 6" (100...150 mm)	<i>0...10 psi</i> (0...0,6 bar)	<i>0...580 psi</i> (0...40 bar)	Vacuum and compound gauges included
Diaphragm differential pressure gauges	<i>0...100 InH₂O</i> (0...250 mbar)	<i>0...360 psi</i> (0...25 bar)	Max static pressure 60 bar
Diaphragm pressure switches	<i>0...15 psi</i> (0...15 bar)	<i>0...580 psi</i> (0...40 bar)	Vacuum and compound gauges included
Pressure transmitters	<i>0...40 InH₂O</i> (0...100 mbar)	<i>0...580 psi</i> (0...40 bar)	Max static pressure 60 bar

diaphragm seal with threaded connection

MGS9/1B

MGS9/1B0

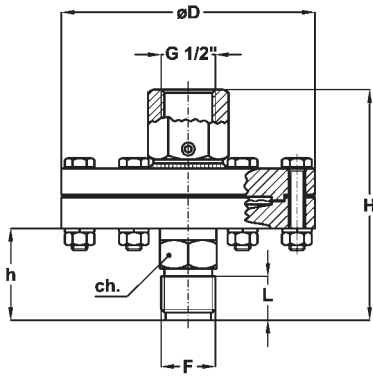

MGS9/1BS

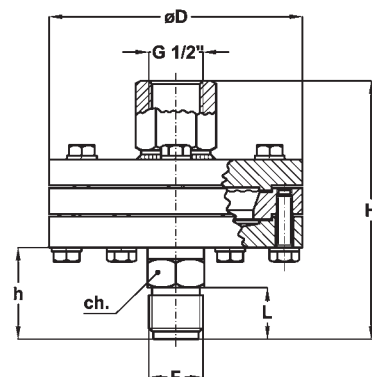

F	ø D	ch	H	h	L	Weight
41M -G 1/2 B	3.85"	0.87"	3.50"	1.40"	0.78"	3.13 lbs
43M -1/2 NPT*	(98)	(22)	(89)	(35,5)	(20)	(1,300 kg)

dimensions : inches (mm)

F	D	ch	H	h	L	Weight
41M -G 1/2 B	3.85"	0.87"	3.94"	1.40"	0.78"	3.90 lbs
43M -1/2 NPT*	(98)	(22)	(100)	(35,5)	(20)	(1,770 kg)

dimensions : inches (mm)

*Not available with PTFE coated process connections.

ASSEMBLING

All diaphragm seals are mounted on the instruments and fixed by an aluminium protection label. For applications with capillary: should diaphragm seal and instrument not be at the same level, instrument adjustment is required). (For use and installation, see data sheet "4")

D - Direct	9 - Capillary AISI304 st.st., AISI304 st.st. armoured, 36.37" max (6 mt max)
I - Nude capillary AISI304, 36.37" max (6 mt max)	6 - Capillary AISI316 st.st., AISI316 st.st. armoured, 36.37" max (6 mt max)

FILLING FLUIDS and process fluid temperature

Fluid	Vacuum	Pressure	Fluid	Vacuum	Pressure
Standard silicon oil	-40...+122°F (-40...+100°C)	-40...+302°F (-40...+150°C)	E - Fluorinated liquid "E"	-40...+212°F (-40...+100°C)	-40...+302°F (-40...+150°C)
B - Silicon oil "B"	-40...+302°F (-40...+150°C)	-40...+482°F (-40...+250°C)	F - Silicon oil "C"	-130...+176°F (-90...+80°C)	-130...+302°F (-90...+150°C)
C - Silicon oil "C"	-14...+392°F (-10...+200°C)	-14...+662°F (-10...+350°C)	G - Mineral food oil "G"	-14...+302°F (-10...+150°C)	-14...+392°F (-10...+200°C)
D - Silicon oil "D"	-14...+392°F (-10...+200°C)	-14...+752°F (-10...+400°C)			

OPTIONS

Description	MGS9/1B0	MGS9/1BS
C05 - Helium Test	◆	◆
E30 - Nace version MR0103/MR0175 (ISO 15156) (1)	◆	◆
TS5 - Washing plug - 1/4" NPT (4)	◆	◆
P04 - Dye penetrant test	◆	◆
P02 - Oxygen degreasing(2)	◆	◆
MPP - PTFE diaphragm protection, for temperature up to 302 °F (150 °C) (3)	◆	◆
Special process connections (4) : 1/4" NPTF; 1/2" NPTF; 3/4" NPTF; 3/4" NPTM	◆	◆

- (1) Stainless steel process connection and Monel 400 or Hastelloy C276 diaphragm
- (2) To be ordered together with fluorinated liquid filling
- (3) Except for pressure gauges and vacuum gauges
- (4) Stainless steel process connection only

"HOW TO ORDER" SEQUENCE

Section/Model/Connection material/Diaphragm material/Process Connection/Instrument connection/Assembling / Options

4 1B0 5, N, 6 4, 6, 9 41M 41F - G 1/2 F D B...G
1BS 9, F, V B, J, I 43M 1, 9, 6 C05...MPP
U, 8, E 43F
C, 2

back side diaphragm seal for high pressure, with threaded connection



PED 2014/68/EU

Diaphragm seals are designed to isolate the sensing element of pressure gauges, pressure switches and electronic pressure transmitter from process fluids which may be corrosive, viscous, sedimentous and/or with a high temperature. The diaphragm is mechanically clamped between the upper housing and intermediate ring and is leak proof tested to guarantee fill fluid separation from process fluid. Model MGS9/1A0 is cleaned by removing the lower housing from the intermediate ring. Both models are without sealing gaskets. This construction feature and its compact design suits many application that require frequent maintenance, for model MGS9/1A0.

4.1AS - MGS9/1AS

Working pressure: from 0...6000 to 0...8000 psi; (from 0...400 bar to 0...600 bar).

Working temperature: -49...+302 °F (-45°C...+150°C).

Accuracy*: (add to instrument accuracy) ±0,5% for direct mounting; ±1% for capillary mounting.

Instrument connection: AISI 316 st. st.

Diaphragm: metallic seal,

4 - AISI 316L st.st.,

9 - Hastelloy C276,

6 - Monel 400.

Process connection:

4 - AISI 316 st.st.,

5 - AISI 316 L st.st.

Clamp bolts: high tensile carbon steel.

Filling liquid: silicon oil.

4.1A0 - MGS9/1A0

Working pressure: from 0...1000 to 0...6000 psi; (from 0...60 bar to 0...400 bar).

Working temperature: -49...+302 °F (-45°C...+150°C).

Accuracy*: (add to instrument accuracy) ±0,5% for direct mounting; ±1% for capillary mounting.

Instrument connection: AISI 316 st. st.

Diaphragm: metallic seal,

4 - AISI 316L st.st.,

9 - Hastelloy C276,

6 - Monel 400.

Intermediate ring: AISI 316 st.st.

Process connection:

4 - AISI 316 st.st.,

5 - AISI 316 L st.st.

Clamp bolts: stainless steel.

Filling liquid: silicon oil.

* at 68°F (20 °C) process temperature (or state temperature when ordering)

back side diaphragm seal for high pressure, with threaded connection

MGS9/1A

MGS9/1AS

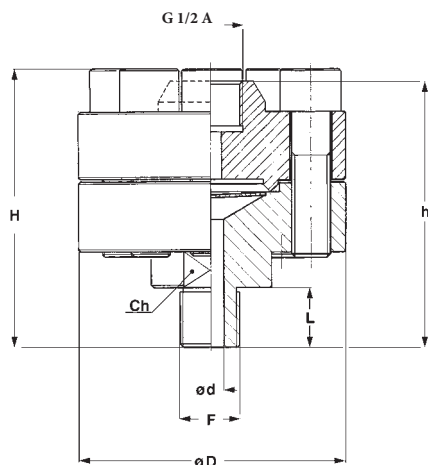

MGS9/1A0

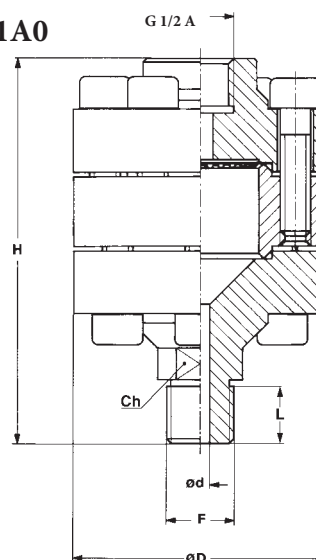

F	d	H	h	L	D	Ch
41M - G 1/2 B	0.27"	3.66"	3.50"	0.78"	3.50"	1.41"
43M - 1/2 NPT	(7)	(93)	(89)	(20)	(89)	(36)

F	d	H	L	D	Ch
41M - G 1/2 B	0.23"	4.78"	0.78"	3.14"	0.86"
43M - 1/2 NPT	(6)	(121,5)	(20)	(80)	(22)

dimensions : inches (mm)

ASSEMBLING

All diaphragm seals are mounted on the instruments and fixed by an aluminium protection label. For applications with capillary: should diaphragm seal and instrument not be at the same level, instrument adjustment is required). (For use and installation, see data sheet "4")

D - Direct	9 - Capillary AISI304 st.st., AISI304 st.st. armoured, 36.37" max (6 mt max)
1 - Nude capillary AISI304, 36.37" max (6 mt max)	6 - Capillary AISI316 st.st., AISI316 st.st. armoured, 36.37" max (6 mt max)

FILLING FLUIDS and process fluid temperature

Fluid	Vacuum	Pressure	Fluid	Vacuum	Pressure
Standard silicon oil	-40...+122°F (-40...+100°C)	-40...+302°F (-40...+150°C)	E - Fluorinated liquid "E"	-40...+212°F (-40...+100°C)	-40...+302°F (-40...+150°C)
B - Silicon oil "B"	-40...+302°F (-40...+150°C)	-40...+482°F (-40...+250°C)	F - Silicon oil "C"	-130...+176°F (-90...+80°C)	-130...+302°F (-90...+150°C)
C - Silicon oil "C"	-14...+392°F (-10...+200°C)	-14...+662°F (-10...+350°C)	G - Mineral food oil "G"	-14...+302°F (-10...+150°C)	-14...+392°F (-10...+200°C)
D - Silicon oil "D"	-14...+392°F (-10...+200°C)	-14...+752°F (-10...+400°C)			

OPTIONS

R20 - Adaptor G 1/2 A M/F
R22 - Adaptor G 1/2 A M x 1/2 - 14 NPT F
R21 - Adaptor G 1/2 A M x 1/4 - 18 NPT F
T11 - Washing plug
C05 - Helium Test
E30 - Nace version MR0103 (1) - MR0175 (ISO 15156) (2)

(1) Stainless steel process connection and Monel 400 or Hastelloy C276 diaphragm. (2) Wetted parts hastelloy C276

"HOW TO ORDER" SEQUENCE

Section/Model/Connection material/Diaphragm material/Process Connection/Instrument connection/Assembling/Options

4 1AS 4 4, 9, 6 41M 41F - G 1/2 F D B...G
1A0 5 43M 1, 9, 6 R20...E30

back side diaphragm seals, with threaded connection



Diaphragm seals are designed to isolate the sensing element of pressure gauges, pressure switches and electronic pressure transmitter from process fluids which may be corrosive, viscous, sedimentous and/or with a high temperature. The diaphragm is welded to the top housing and leak proof tested, to guarantee a separation between process fluid and fill transmission fluid. The upper part is detachable from the lower process side for cleaning. This construction feature and its compact design suits many application that require frequent maintenance.

4.111 - MGS9/111

Working pressure: *from 0...100 to 3000 psi (from 0...6 bar to 0...250 bar).*

Working temperature: *-49...+302°F (-45°C...+150°C.)*

Accuracy*: (add to instrument accuracy) $\pm 0,5\%$ for direct mounting;
 $\pm 1\%$ for capillary mounting.

Instrument connection: AISI 316 st.st.

Diaphragm: welded,

4 - AISI 316L st.st.,

9 - Hastelloy C276,

6 - Monel 400.

Hexagonal nut: AISI 304 st.st.

Process connection:

4 - AISI 316 st.st.

Filling liquid: silicon oil.

* at 68°F (20 °C) process temperature (or state temperature when ordering)

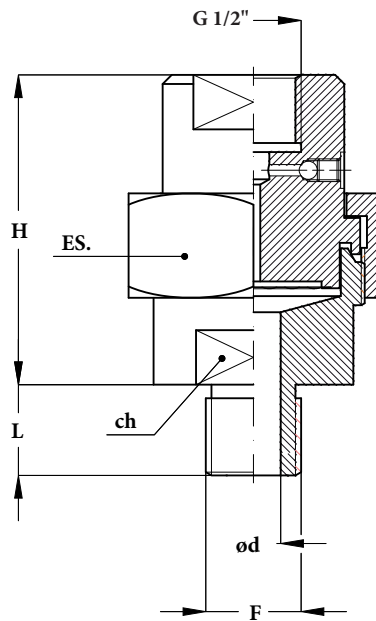

F	d	H	L	ES.	Ch
41M G 1/2 A	0.47" (12)	2.67" (68)	0.78" (20)	2.16" (55)	1.41" (36)
43M 1/2-14 NPT	0.47" (12)	2.67" (68)	0.78" (20)	2.16" (55)	1.41" (36)
43F 1/2-14 NPT F		2.67" (68)		2.16" (55)	1.41" (36)
53F 3/4-14 NPT F		2.67" (68)		2.16" (55)	1.41" (36)

dimensions : inches (mm)

ASSEMBLING

All diaphragm seals are mounted on the instruments ad fixed by an aluminium protection label. For applications with capillary: shoul diaphragm seal and instrument not be at the same level, instrument adjustment is required). (For use and installation, see data sheet "4")

D - Direct	9 - Capillary AISI304 st.st., AISI304 st.st. armoured, 36.37" max (6 mt max)
I - Nude capillary AISI304, 36.37" max (6 mt max)	6 - Capillary AISI316 st.st., AISI316 st.st. armoured, 36.37" max (6 mt max)

FILLING FLUIDS and process fluid temperature

Fluid	Vacuum	Pressure	Fluid	Vacuum	Pressure
Standard silicon oil	-40...+122°F (-40...+100°C)	-40...+302°F (-40...+150°C)	E - Fluorinated liquid "E"	-40...+212°F (-40...+100°C)	-40...+302°F (-40...+150°C)
B - Silicon oil "B"	-40...+302°F (-40...+150°C)	-40...+482°F (-40...+250°C)	F - Silicon oil "C"	-130...+176°F (-90...+80°C)	-130...+302°F (-90...+150°C)
C - Silicon oil "C"	-14...+392°F (-10...+200°C)	-14...+662°F (-10...+350°C)	G - Mineral food oil "G"	-14...+302°F (-10...+150°C)	-14...+392°F (-10...+200°C)
D - Silicon oil "D"	-14...+392°F (-10...+200°C)	-14...+752°F (-10...+400°C)			

OPTIONS

C05 - Helium Test
E30 - Nace version MR 01.03 (1)
P02 - Oxygen degreasing (2)
P04 - Dye penetrant test

- (1) Stainless steel process connection and Monel 400 or Hastelloy C276 diaphragm
- (2) To be ordered together with fluorinated liquid filling

"HOW TO ORDER" SEQUENCE

Section/Model/Connection material/Diaphragm material/Process Connection/Instrument connection/Assembling/Options

4 111 4 4, 6, 9 41M 41F - G 1/2 F D B...G
43M 1, 9, 6 C05...P04
43F
53F

“continuous duty” diaphragm seal, welded, with threaded connection



Diaphragm seals are designed to isolate the sensing element of pressure gauges, pressure switches and electronic pressure transmitter from process fluids which may be corrosive, viscous, sedimentous and/or with a high temperature. In case of accidental removal of the instrument or of liquid filling leak the diaphragm will place on the upper cup preventing any damage and any process liquid leak. Thanks to an exclusive calibration system the pressure gauge should stand an overpressure of 210bar without the help of any pressure control switch .

4.2B0 - MGS9/2B

Design: ASME B40.2

Working pressure: *from -30...0 INHG to 0...2320 psi (from -1...0 to 0...160 bar).*

“Continuous duty”: *3000 psi (210 bar) as per ASME B40.2.*

Process temperature: *-49...+302°F (-45°C...+150°C.)*

Accuracy (1): (add to instrument accuracy) $\pm 0,5\%$ for direct mounting, $\pm 1\%$ for capillary mounting.

Instrument connection: AISI 304 st.st.

Diaphragm material:

4 - AISI 316L st.st.,

6 - Monel 400,

9 - Hastelloy C 276,

B - Tantalum,

J - Alloy 600;

I - Alloy 825;

U - 25.22.2.

Gaskets: PTFE up to $+482^{\circ}\text{F}$ ($+250^{\circ}\text{C}$).

Process connection:

5 - AISI 316L st.st.

6 - Monel 400

9 - Hastelloy C 276.

Clamp nuts and bolts: high resistance steel.

Filling liquids: Silicon oil.

Special overpressure: *3000 psi for 1 hour (210 bar) (2) (3).*

(1) at 68°F (20°C) process temperature (or state temperature when ordering)

(2) on request only, pressure gauge/pressure switch assembling only

(3) Vacuum and compound gauges excluded

**"continuous duty" diaphragm seal
welded, with threaded connection**

MGS9/2B

RS-08/14

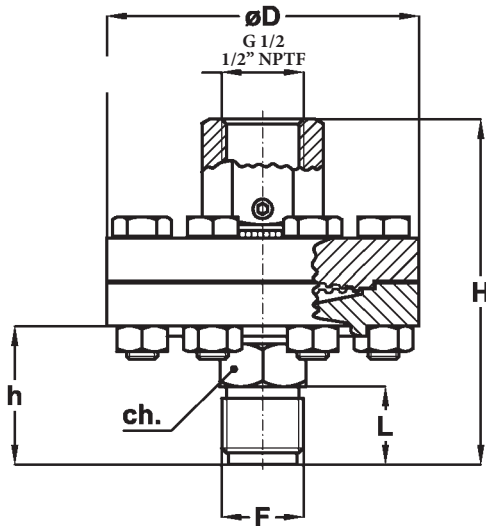

F	D	ch	H	h	L	Weight
41M - G 1/2 B	3.15"	0.87"	3.54"	2.79"	0.79"	2.36 lbs
43M - 1/2 NPT	(80)	(22)	(90)	(35,5)	(20)	(1,070 kg)

dimensions : inches (mm)

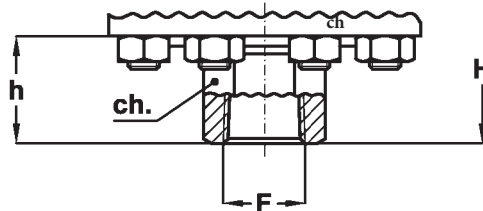

F	D	ch	H	h	Weight
43F 1/2 NPT F	3.15"	1.06"	3.23"	1.08"	2.34 lbs
	(80)	(27)	(82)	(27,5)	(1,060 kg)

dimensions : inches (mm)

ASSEMBLING

All diaphragm seals are mounted on the instruments and fixed by an aluminium protection label. For applications with capillary: should diaphragm seal and instrument not be at the same level, instrument adjustment is required). (For use and installation, see data sheet "4")

D - Direct	9 - Capillary AISI304 st.st., AISI304 st.st. armoured, 36.37" max (6 mt max)
I - Nude capillary AISI304, 36.37" max (6 mt max)	6 - Capillary AISI316 st.st., AISI316 st.st. armoured, 36.37" max (6 mt max)

FILLING FLUIDS and process fluid temperature

Fluid	Vacuum	Pressure	Fluid	Vacuum	Pressure
Standard silicon oil	-40...+122°F (-40...+100°C)	-40...+302°F (-40...+150°C)	E - Fluorinated liquid "E"	-40...+212°F (-40...+100°C)	-40...+302°F (-40...+150°C)
B - Silicon oil "B"	-40...+302°F (-40...+150°C)	-40...+482°F (-40...+250°C)	F - Silicon oil "C"	-130...+176°F (-90...+80°C)	-130...+302°F (-90...+150°C)
C - Silicon oil "C"	-14...+392°F (-10...+200°C)	-14...+662°F (-10...+350°C)	G - Mineral food oil "G"	-14...+302°F (-10...+150°C)	-14...+392°F (-10...+200°C)
D - Silicon oil "D"	-14...+392°F (-10...+200°C)	-14...+752°F (-10...+400°C)			

OPTIONS

C05 - Helium Test (1)
E30 - Nace version MR0103/MR0175 (ISO 15156) (2)
TS5 - AISI316L stainless steel washing plug, 1/4" NPT
P04 - Dye penetrant test
BAI - Stainless steel fixing bolts (5)
S40 - Max overpressure 3000 psi (210 bar) (3) (4)
MPP - PTFE diaphragm protection, for temperature up to 302 °F (150 °C) (3)
Special process connections (1) : 1/4" NPTF; 3/4" NPTF; 3/4 NPTM

- (1) on models with AISI316L process connection only
- (2) Stainless steel process connection and Monel 400 or Hastelloy C276 diaphragm

- (3) Except for vacuum and compound gauges
- (4) for pressure gauge/pressure switch assembling only
- (5) max 100 bar

"HOW TO ORDER" SEQUENCE

Section/Model/Connection material/Diaphragm material/Process Connection/Instrument connection/Assembling/Options

4	2B0	5	4, 6, 9	41M	41F - G 1/2 F	D	B...G
		6	B, J, I	43M	43F - 1/2NPT F	1, 9, 6	C05...MPP
		9	U	43F			

Copyright © Nuova Fima srl. All rights reserved. Any part of this publication should not be reproduced without a written Nuova Fima's srl approval



IN ORDER TO IMPROVE THEIR PRODUCTION, MESSRS. NUOVA FIMA RESERVE THE RIGHT TO THEMSELVES TO MAKE ALL THE MODIFICATIONS THAT THEY DEEM INDISPENSABLE AT ANY TIME. UPDATED DATA SHEETS ARE AVAILABLE ON SITE: www.nuovafima.com

compact diaphragm seals, welded



Diaphragm seals are designed to isolate the sensing element of pressure gauges and pressure switches from process fluids that may be corrosive, viscous, sedimentous and/or with a high temperature. The diaphragm is welded to the body, to ensure separation of the filling fluid from the process medium. The threaded connection make it easy to use on all applications where the reduced size of the system is important and also where gauges of 2.5" (63 mm) diameter are required.

4.MIA - MGS9/MINI/A

Working pressure: up to 0...6000 *psi* (up to 0...400 bar), as from RANGES table.

Working temperature: -49...302°F (-45...+150°C).

Accuracy(1): (add to instrument accuracy) ±1,0 % for direct mounting; ± 1% for capillary mounting.

Instrument connection: AISI 316 L st.st.

Diaphragm: welded,

4 - AISI 316 L st.st.

Process connection:

5 - AISI 316 L st.st.

Filling liquid: silicon oil.

4.MIB - MGS9/MINI/B

Working pressure: up to 0...1000 *psi* (up to 0...60 bar), as from RANGES table.

Other features: as model MGS9/MIA.

(1) at 68°F (20 °C) process temperature (or state temperature when ordering)

RANGES

Gauge DS	MGS9/MIA	MGS9/MIB
2.5" (63 mm)	0...60/0...6000 <i>psi</i> (0...4/0...400 bar)	-30...0 <i>InHG</i> /0...1000 <i>psi</i> (-1...0/0...60 bar)
4"...6" (100...150 mm)	0...200/0...6000 <i>psi</i> (0...16/0...400 bar)	

ASSEMBLING

D - All diaphragm seals are mounted directly on the instruments.

All diaphragm seals are mounted on the instruments ad fixed by an aluminium protection label.

MGS9/MIA

MGS9/MIB

f
41F - G 1/2
21F - G 1/4
23F - 1/4-18 NPT

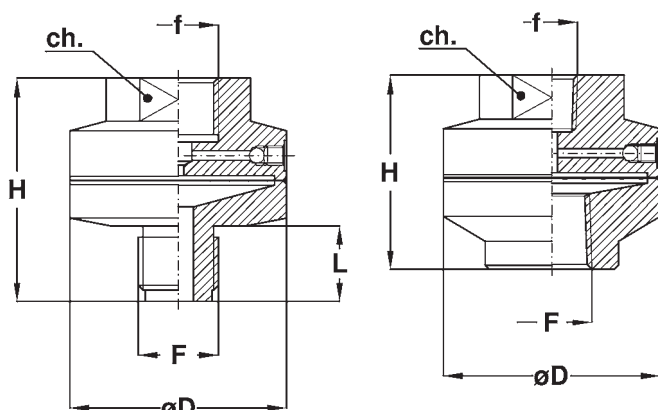
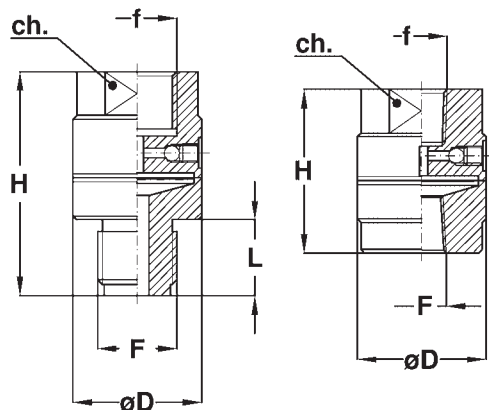

F (1)	D	H	Ch	L
23F 1/4-18 NPT F	1.33" (34)	1.69" (43)	1.06" (27)	-
43M 1/2-14 NPT M	1.33" (34)	2.32" (59)	1.06" (27)	0.78" (20)
43F 1/2-14 NPT F	1.33" (34)	1.69" (43)	1.06" (27)	-
41M G 1/2 B	1.33" (34)	2.32" (59)	1.06" (27)	0.78" (20)

(1) other threads available on request
dimensions : inches (mm)

F (1)	D	H	Ch	L
23F 1/4-18 NPT F	2.24" (57)	2" (51)	1.25" (32)	-
43M 1/2-14 NPT M	2.24" (57)	2.32" (59)	1.25" (32)	0.78" (20)
43F 1/2-14 NPT F	2.24" (57)	2" (51)	1.25" (32)	-
41M G 1/2 B	2.24" (57)	2.32" (59)	1.25" (32)	0.78" (20)

(1) other threads available on request
dimensions : inches (mm)

FILLING FLUIDS and process fluid temperature

Fluid	Vacuum	Pressure	Fluid	Vacuum	Pressure
Standard silicon oil	-40...+122°F (-40...+100°C)	-40...+302°F (-40...+150°C)	E - Fluorinated liquid "E"	-40...+212°F (-40...+100°C)	-40...+302°F (-40...+150°C)
B - Silicon oil "B"	-40...+302°F (-40...+150°C)	-40...+482°F (-40...+250°C)	F - Silicon oil "C"	-130...+176°F (-90...+80°C)	-130...+302°F (-90...+150°C)
C - Silicon oil "C"	-14...+392°F (-10...+200°C)	-14...+662°F (-10...+350°C)	G - Mineral food oil "G"	-14...+302°F (-10...+150°C)	-14...+392°F (-10...+200°C)
D - Silicon oil "D"	-14...+392°F (-10...+200°C)	-14...+752°F (-10...+400°C)			

"HOW TO ORDER" SEQUENCE

Section/Model/Connection material/Diaphragm material/Process Connection/Instrument connection/Assembling/Options

4 MIA 5 4 41M 21F D B...G
MIB 43M 23F
23F 41F
43F

sanitary diaphragm seal threaded process connection DIN, IDF/ISS



74-06

Autorization NO. 1599

Diaphragm seals are designed to isolate the sensing element of pressure gauges and pressure switches from process fluids which may be corrosive, viscous, sedimentous and/or with a high temperature. The diaphragm is welded to the upper body, to ensure separation of filling fluid from process medium. Designed in accordance with food and pharmaceutical standards to permit easy removal from the plant whilst maintains the hygienic feature during frequent cleaning.

4.SAN - MGS9/SA

Design: 74-06 SSI.

Working pressure: from 0...30 to 0...600 psi (from 0...1 to 0...40 bar).
Minimum working pressure as from MINIMUM RANGES table .

Process temperature: -4...+212°F (-20°C...+100°C);
Max 284°F (140 °C) for 30 minutes during cleaning stage (C.I.P.) ¹ and sterilization (S.I.P) ².

Accuracy ²: (add to instrument accuracy) ±0,5% for direct mounting.

Instrument connection: AISI 316 st.st..

Diaphragm: welded, 4 - AISI 316 L st.st.

Filling liquid: mineral oil (FDA approved) for food industry.

Process connection: AISI 316 (Cod. 4)st.st. as per:

-DIN 11851;

-IDF/ISS;

see "MINIMUM RANGES" table for dimensions, with finishing Ra ≤ 0,76 µm (welded parts included), as per ASME BPE SF3.

Union nut: AISI 304 st.st.

1) C.I.P. = Cleaned In Place

2) S.I.P. = Steamed In Place - available for ranges > 1bar when steam pressure does not exceed the max admissible pressure on the connected instrument

3) at +68°F (20 °C) process fluid temperature, or state temperature when ordering.

MINIMUM RANGES

Process connection	DN	Female with union nut		Male	
		DS 2.5" (63mm)	DS 4" (100mm)	DS 2.5" (63mm)	DS 4" (100mm)
DIN 11851	25	0...60 psi (0...4 bar)	0...60 psi (0...4 bar)	0...100 psi (0...6 bar)	
	32		0...60 psi (0...4 bar)		0...60 psi (0...4 bar)
	40		0...30 psi (0...1,6 bar)		0...60 psi (0...4 bar)
	50		0...15 psi (0...1 bar)		0...30 psi (0...1,6 bar)
IDF/ISS	1" 1/2		0...60 psi (0...4 bar)		0...60 psi (0...4 bar)
	2"		0...30 psi (0...1,6 bar)		0...30 psi (0...1,6 bar)

ASSEMBLING

D - All diaphragm seals are mounted directly on the instruments.

All diaphragm seals are mounted on the instruments and fixed by an aluminium protection label.

sanitary diaphragm seal
threaded process connection DIN, IDF/ISS

MG9/SA

R7-02/6

Female with union nut

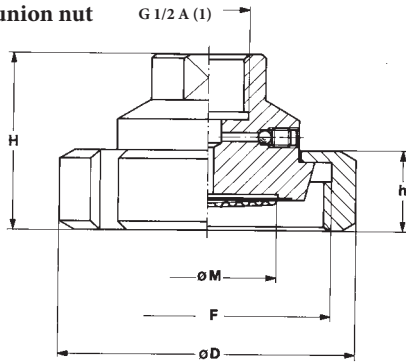

(1) DN 25 = G 1/2 A, G 1/4 A; 1" = G 1/4 A

DN	Code	H	h	D	M	F (DIN 405)
25	QHF	*1.81" (*46)	0.82" (21)	2.48" (63)	1.18" (30)	Rd 52 x 1/6
32	RHF	1.81" (46)	0.82" (21)	2.75" (70)	1.18" (30)	Rd 58 x 1/6
40	SHF	1.81" (46)	0.82" (21)	3.07" (78)	1.57" (40)	Rd 65 x 1/6
50	THF	1.85" (47)	0.86" (22)	3.62" (92)	1.96" (50)	Rd 78 x 1/6

(*) G 1/4 A : 1.63" (41,5 mm)

Male

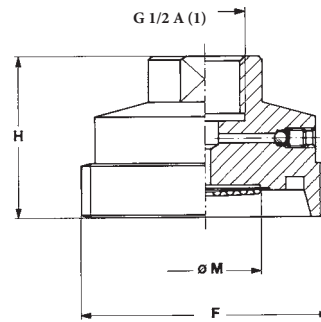

(1) DN 25 and 1" = G 1/4 A

DN	Code	H	M	F (DIN 405)
25	QHM	1.45" (37)	0.78" (20)	Rd 52 x 1/6
32	RHM	1.65" (42)	1.18" (30)	Rd 58 x 1/6
40	SHM	1.65" (42)	1.18" (30)	Rd 65 x 1/6
50	THM	1.65" (42)	1.57" (40)	Rd 78 x 1/6

dimensions : inches (mm)

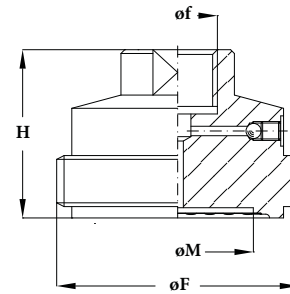
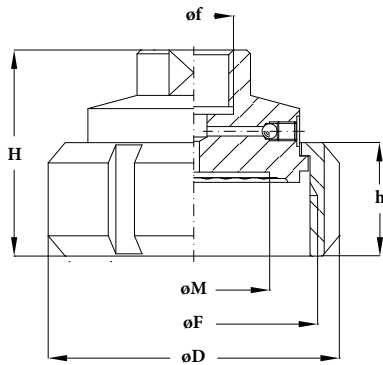

IDF/ISS

DN	Code	H	h	D	M	F (ACME)
1" 1/2	AMF	2.14"	1.18"	2.51"	1.18"	2" 1/32 x 8
2"	BMF	2.14"	1.18"	3.03"	1.57"	2" 9/16 x 8

IDF/ISS

DN	Code	H	M	F (ACME)
1" 1/2	AMM	1.75"	1.18"	2" 1/32 x 8
2"	BMM	1.75"	1.57"	2" 9/16 x 8

dimensions : inches

OPTIONS

P04 - Dye penetrant test	C05 - Helium Test
---------------------------------	--------------------------

"HOW TO ORDER" SEQUENCE

Section/Model/Connection material/Diaphragm material/Process Connection/Instrument connection/Assembling/Options
4 SAN 4 4 QHF...THM 41F - G 1/2 F D C05, P04
AMF...BMM



clamp connection diaphragm seal



74-06

Autorization NO. 1599



Diaphragm seals are designed to isolate the sensing element of pressure gauges and pressure switches from process fluids that may be corrosive, viscous, sedimentous and/or with a high temperature. The diaphragm is welded to the upper body, to ensure separation of the filling fluid from the process medium. Faced diaphragm position enables deep cleaning of the surface while the quick-connection Clamp enables frequent removal from the process during sterilization and cleaning operations, a common requirement in the food processing industry.

4.ALI.4.---- - MGS9/AL

Design: 74-06 SSI.

Working pressure: from 0...15 to 0...600 psi (from 0...1 to 0...40 bar), as from RANGE table .

Process temperature: -4...+212°F (-20°C...+100°C);
Max 284°F (140 °C) for 30 minutes during cleaning stage (C.I.P.) ¹ and sterilization (S.I.P) ².

Accuracy ³: (add to instrument accuracy) ±0,5% max for direct mounting.

Diaphragm: welded, 4 - AISI 316L st.st.

Process connection : 4 - AISI 316 st.st. with finishing Ra ≤0,76 μm (welded parts included), as per ASME BPE SF3.

Filling liquid: mineral oil (FDA approved)for food industry.

4.ALI.4.TA3- - MGS9/AL - 150°C

Process temperature: -4...+302°F (-20°C...+150°C)

Other features: as Standard Model.

1) C.I.P. = Cleaned In Place

2) S.I.P. = Steamed In Place - available for ranges > 1bar when steam pressure does not exceed the max admissible pressure on the connected instrument

3) at +68°F (20 °C) process fluid temperature, or state temperature when ordering.

RANGES (1)

Pressure gauges DS	1" Clamp	1" 1/2 Clamp	2" Clamp	2" 1/2 Clamp	3" Clamp
2.5" (63mm)	0...100/0...600 psi (0...6/0...40 bar)	0...60/0...600 psi (0...4/0...40 bar)			
4" (100mm)		0...60/0...600 psi (0...4/0...40 bar)	0...30/0...600 psi (0...1,6/0...40 bar)	0...15/0...600 psi (0...1/0...40 bar)	0...15/0...400 psi (0...1/0...25 bar)
6" (150mm)		0...100/0...600 psi (0...6/0...40 bar)	0...30/0...600 psi (0...2,5/0...40 bar)	0...30/0...600 psi (0...1,6/0...40 bar)	0...30/0...400 psi (0...1,6/0...25 bar)

(1) Vacuum and compound are available upon request

MGS9/AL - STD
cod. ----

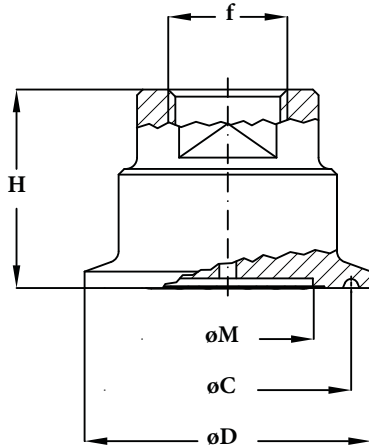

MGS9/AL - 150°C
cod. TA3-

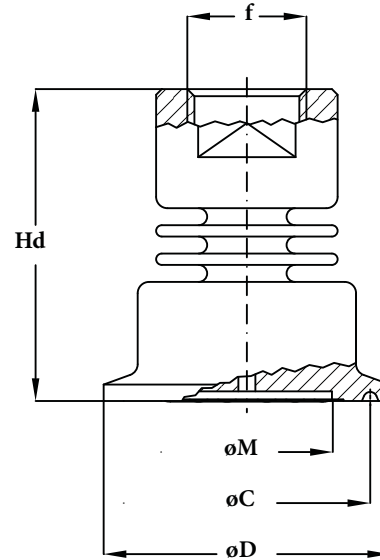

DN Clamp	Code	C	H	Hd	D	f	M
1"	6T-	1,71"	1,18"	1,18"	1,98"	21F - G 1/4 A	0,78"
1" 1/2	AT-	1,71"	1,37"	1,37"	1,98"	21F - G 1/4 A 41F - G 1/2 A	1,18"
2"	BT-	2,22"	1,37"	1,37"	2,51"	41F - G 1/2 A	1,57"
2" 1/2	DT-	2,77"	1,37"	1,37"	3,05"	41F - G 1/2 A	1,96"
3"	ET-	3,29"	1,37"	1,37"	3,58"	41F - G 1/2 A	2,56"

dimensions : inches

ASSEMBLING

D - All diaphragm seals are mounted directly on the instruments.
All diaphragm seals are mounted on the instruments and fixed by an aluminium protection label.

FINISHING

0 - Ra ≤ 0,76 µm, as per ASME BPE SF1	(1)
A - Ra ≤ 0,51 µm, as per ASME BPE SF1	(1)
B - Ra ≤ 0,38 µm, as per ASME BPE SF4 - electropolished	(1)

(1) welded parts included

OPTIONS

C05 - Helium Test
P04 - Dye penetrant test

"HOW TO ORDER" SEQUENCE

Section/Model/Connection material/Version/Diaphragm material/Process Connection/Finishing/Instrument connection/Assembling/Options

4 ALI 4 ---- 4 6T-...ET- 0 21F - G 1/4 F D C05...P04
TA3- 41F - G 1/2 F
B

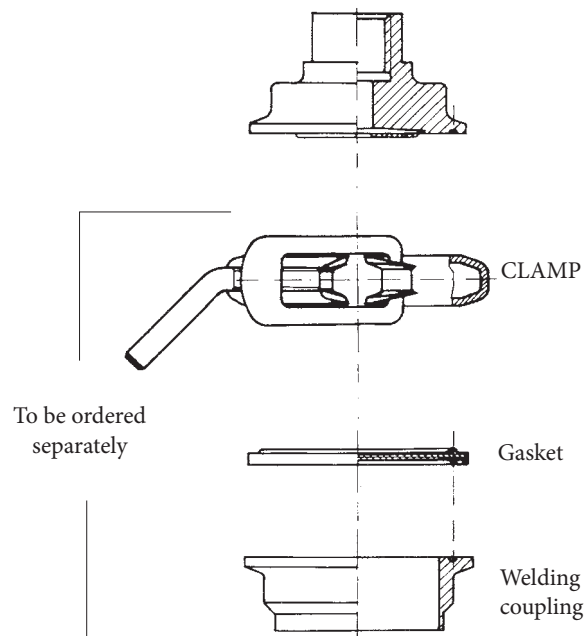

diaphragm seal for DS 2.5" (63mm) pressure gauges, with threaded connection



Diaphragm seals are designed to isolate the sensing element of pressure gauges DS 63 and electronic transmitter from process fluids which may be corrosive, viscous, sedimentous and/or with a high temperature. The diaphragm is welded to the top housing and leak proof tested, to guarantee a separation between process fluid and fill transmission fluid. This construction feature and its compact design suits many application that require frequent maintenance.

4.367 - MGS9/367

Working pressure : *from 0...600 to 0...6000 psi (from 0...40 to 0...400 bar).*

Process temperature: *-49...+302°F (-45°C...+150°C).*

Accuracy*: (add to instrument accuracy) $\pm 1\%$ for direct mounting only.

Diaphragm: welded,

4 - AISI 316 L st.st.

Process connection:

4 - AISI 316 st.st.

Filling liquid: silicone oil.

* at 68°F (20 °C) process temperature (or state temperature when ordering)

diaphragm seal for DS 2.5" (63mm) pressure gauges, with threaded connection

MGS9/367

MS-08/14

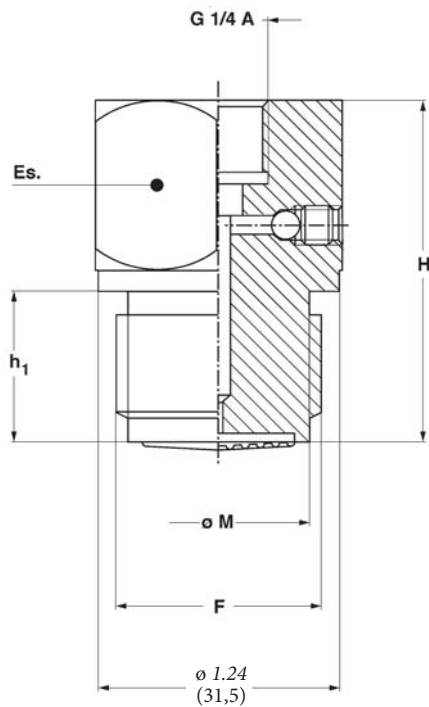

F	M	h ₁	H	Es.
51M	0.92"	0.62"	1.43"	1.25"
G 3/4 M	(23,5)	(16)	(36,5)	(32)

dimensions : inches (mm)

ASSEMBLING

D - All diaphragm seals are mounted directly on the instruments.

All diaphragm seals are mounted on the instruments and fixed by an aluminium protection label.

FILLING FLUIDS and process fluid temperature

Fluid	Vacuum	Pressure	Fluid	Vacuum	Pressure
Standard silicon oil	-40...+122°F (-40...+100°C)	-40...+302°F (-40...+150°C)	E - Fluorinated liquid "E"	-40...+212°F (-40...+100°C)	-40...+302°F (-40...+150°C)
B - Silicon oil "B"	-40...+302°F (-40...+150°C)	-40...+482°F (-40...+250°C)	F - Silicon oil "C"	-130...+176°F (-90...+80°C)	-130...+302°F (-90...+150°C)
C - Silicon oil "C"	-14...+392°F (-10...+200°C)	-14...+662°F (-10...+350°C)	G - Mineral food oil "G"	-14...+302°F (-10...+150°C)	-14...+392°F (-10...+200°C)
D - Silicon oil "D"	-14...+392°F (-10...+200°C)	-14...+752°F (-10...+400°C)			

OPTIONS

C05 - Helium Test

P04 - Dye penetrant test

"HOW TO ORDER" SEQUENCE

Section/Model/Connection material/Diaphragm material/Process Connection/Instrument connection/Assembling/Options

4 367 4 4 51M 21F - G 1/4 F D B...G C05, P04

back side diaphragm seals, with flanged connection



Diaphragm seals are designed to isolate the sensing element of pressure gauges and pressure switches from process fluids which may be corrosive, viscous, sedimentous and/or with a high temperature and pressure. An elastic diaphragm, mechanically clamped, fitted to a leak proof check, guarantees the separation of the process fluid from the transmission fill fluid. The mechanical sealing of the diaphragm guarantees the application of the system at high process fluid temperature avoiding the problems caused by gaskets.

4.3A0 - MGS9/3A

Working pressure: from 0...1000 to 3000 psi (from 0...60 bar to 0...250 bar).

Working temperature: -49...+302°F (-45°C...+150°C.)

Accuracy*: (add to instrument accuracy) ±0,5% for direct mounting; ± 1% for capillary mounting.

Instrument connection: AISI 316 st.st.

Diaphragm: welded, AISI 316L st.st. (cod. **4**), Monel 400 (cod. **6**), Hastelloy C276 (cod. **9**), Hastelloy B2 (cod. **1**), Tantalum (cod. **B**), Titanium (cod. **2**).

Threaded process connection: in AISI 316 st.st. (cod. **4**), AISI 316L st.st. (cod. **5**).

* at +68°F (20 °C) process temperature (or state when ordering)

Dimensions : DN 15...25 and PN 25...100 EN 1092 step seal; 1/2"...1" 1/2 class 600...2500 RF as per ASME B16.5.

EN 1092 flanges finishing: type B1 (PN 2,5...40) = Ra 3,2...12,5 µm (cod. **RF7**); type B2 (PN 63...100) = Ra 0,8...3,2 µm (cod. **RF8**).

ASME flanges finishing: type RF = Ra 125...250 AARH (cod. **RF3**).

Filling liquid: silicon oil.

Fixing bolts: AISI 304 st.st.

ASSEMBLING

All diaphragm seals are mounted on the instruments and fixed by an aluminium protection label. For applications with capillary: should diaphragm seal and instrument not be at the same level, instrument adjustment is required). (For use and installation, see data sheet "4")

D - Direct	9 - Capillary AISI304 st.st., AISI304 st.st. armoured, 36.37" max (6 mt max)
1 - Nude capillary AISI304, 36.37" max (6 mt max)	6 - Capillary AISI316 st.st., AISI316 st.st. armoured, 36.37" max (6 mt max)

FILLING FLUIDS and process fluid temperature

Fluid	Vacuum	Pressure	Fluid	Vacuum	Pressure
Standard silicon oil	-40...+122°F (-40...+100°C)	-40...+302°F (-40...+150°C)	E - Fluorinated liquid "E"	-40...+212°F (-40...+100°C)	-40...+302°F (-40...+150°C)
B - Silicon oil "B"	-40...+302°F (-40...+150°C)	-40...+482°F (-40...+250°C)	F - Silicon oil "C"	-130...+176°F (-90...+80°C)	-130...+302°F (-90...+150°C)
C - Silicon oil "C"	-14...+392°F (-10...+200°C)	-14...+662°F (-10...+350°C)	G - Mineral food oil "G"	-14...+302°F (-10...+150°C)	-14...+392°F (-10...+200°C)
D - Silicon oil "D"	-14...+392°F (-10...+200°C)	-14...+752°F (-10...+400°C)			

OPTIONS

R20 - Adaptor G 1/2 A M/F with filling screw	R21 - Adaptor G 1/2 A M x 1/4 - 18 NPT F with filling screw
E30 - Nace MR0103 version, with Monel 400 or Hastelloy C diaphragm.	

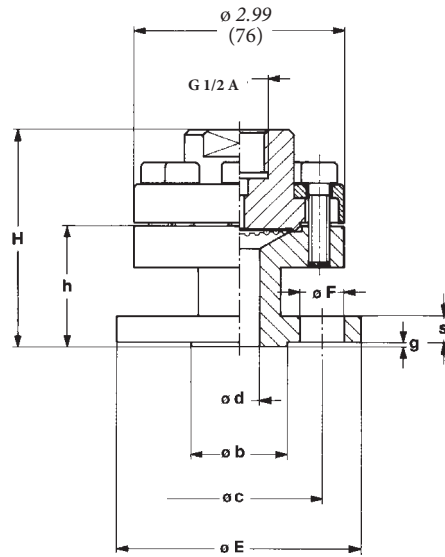

EN 1092 STANDARD

dimensions : mm

DN	PN-bar	Code	h	H	E	b	d	g	c	s	F	N (1)
15	25...40	OSO	47	82,5	95	45	15	2	65	14	14	4
15	63...100	OUO	51	86,5	105	45	15	2	75	18	14	4
20	25...40	PSO	49	84,5	105	58	20	2	75	16	14	4
20	63...100	PUO	57	92,5	130	58	20	2	90	20	18	4
25	25...40	QSO	49	84,5	115	68	25	2	85	16	14	4
25	63...100	QUO	59	94,5	140	68	25	2	100	22	18	4

1) N°holes.

ASME STANDARDS

dimensions : inches

DN	Classe	Code	h	H	E	b	d	g	c	s	F	N (1)
1/2"	600	4DA	2,11"	3,51"	3,74"	1,37"	0,59"	0,24"	2,62"	0,57"	0,62"	4
1/2"	900...1500	4FA	2,70"	4,10"	4,74"	1,37"	0,59"	0,24"	3,24"	0,88"	0,86"	4
3/4"	600	5DA	2,33"	3,73"	4,62"	1,68"	0,78"	0,24"	3,24"	0,62"	0,74"	4
3/4"	900...1500	5FA	2,82"	4,22"	5,11"	1,68"	0,78"	0,24"	3,5"	1,04"	0,86"	4
3/4"	2500	5GA	3,08"	4,48"	5,49"	1,68"	0,78"	0,24"	3,74"	1,25"	0,86"	4
1"	600	6DA	2,39"	3,79"	4,88"	2"	0,98"	0,24"	3,5"	0,68"	0,74"	4
1"	900...1500	6FA	3,10"	4,5"	5,86"	2"	0,98"	0,24"	4"	1,12"	1,02"	4
1"	2500	6GA	3,35"	4,75"	6,24"	2"	0,98"	0,24"	4,24"	1,37"	1,02"	4
1" 1/2	600	ADA	1,72"	3,12"	6,12"	2,87"	1,57"	0,24"	4,5"	0,88"	0,86"	4
1" 1/2	900...1500	AFa	2,09"	3,49"	7"	2,87"	1,57"	0,24"	4,87"	1,25"	1,14"	4
1" 1/2	2500	AGA	2,59"	3,98"	7,99"	2,87"	1,57"	0,24"	5,74"	1,75"	1,25"	4

1) N°holes.

"HOW TO ORDER" SEQUENCE

Section / Model / Connection / Diaphragm / Process / Flange / Instrument / Assembling / Options	material	material	connection	connection	connection	connection	connection	connection	connection
4	3A0	4, 5	4, 6, 9	OS0...QU0	RF3...RF8	41F - G 1/2 F	D	B...G	
			2, B, 1	4DA...AGA			1, 9, 6	R20...E30	



back side diaphragm seals, with flanged connection



Diaphragm seals are designed to isolate the sensing element of pressure gauges and pressure switches from process fluids which may be corrosive, viscous, sedimentous and/or with a high temperature and pressure. An elastic diaphragm, mechanically clamped, fitted to a leak proof check, guarantees the separation of the process fluid from the transmission fill fluid.

4.3B0 - MGS9/3B

Instrument type	Minimum range	Maximum range	Notes
Bourdon tube, DS 4", 6" (100...150 mm)	0...10 psi (0...0,6 bar)	0...580 psi (0...40 bar)	Vacuum and compound gauges included
Diaphragm differential pressure gauges	0...100 InH ₂ O (0...250 mbar)	0...360 psi (0...25 bar)	Max static pressure 60 bar
Diaphragm pressure switches	0...15 psi (0...15 bar)	0...580 psi (0...40 bar)	Vacuum and compound gauges included
Pressure transmitters	0...40 InH ₂ O (0...100 mbar)	0...580 psi (0...40 bar)	Max static pressure 60 bar

Working temperature: -49...+302°F (-45°C...+150°C.)

Accuracy*: (add to instrument accuracy) ±0,5% for direct mounting; ± 1% for capillary mounting.

Instrument connection: AISI 304 st.st.

Diaphragm: AISI 316L st.st. (cod. **4**), Monel 400 (cod. **6**), Hastelloy C276 (cod. **9**), Tantalum (cod. **B**), Titanium (cod. **2**) and AISI 316L st.st. PTFE coated (cod. **8**)**.

Gaskets: PTFE (max. 250°C).

Threaded process connection: in AISI 316 st.st. (cod. **4**), AISI 316L st.st. (cod. **5**), AISI 316L st.st. PTFE coated (cod. **N**)**.

Dimensions : DN 15...50 and PN 6...40 EN 1092 step seal; 1/2"...2" class 150...600 RF as per ASME B16.5.

* at +68°F (20 °C) process temperature (or state when ordering)

EN 1092 flanges finishing: type B1 (PN 2,5...40) = Ra 3,2...12,5 µm (cod. **RF7**); type B2 (PN 63...100) = Ra 0,8...3,2 µm (cod. **RF8**).

ASME flanges finishing: type RF = Ra 125...250 AARH (cod. **RF3**).
EN 1092 flanges finishing: type B1 (PN 2,5...40) = Ra 3,2...12,5 µm (cod. **RF7**); type B2 (PN 63...100) = Ra 0,8...3,2 µm (cod. **RF8**).

ASME flanges finishing: type RF = Ra 125...250 AARH (cod. **RF3**).

Filling liquid: silicon oil.

Fixing bolts: AISI 304 st.st.

** max temperature +328°F (+150°C), with PTFE coating

ASSEMBLING

All diaphragm seals are mounted on the instruments and fixed by an aluminium protection label. For applications with capillary: should diaphragm seal and instrument not be at the same level, instrument adjustment is required). (For use and installation, see data sheet "4")

D - Direct	9 - Capillary AISI304 st.st., AISI304 st.st. armoured, 36.37" max (6 mt max)
I - Nude capillary AISI304, 36.37" max (6 mt max)	6 - Capillary AISI316 st.st., AISI316 st.st. armoured, 36.37" max (6 mt max)

FILLING FLUIDS and process fluid temperature

Fluid	Vacuum	Pressure	Fluid	Vacuum	Pressure
Standard silicon oil	-40...+122°F (-40...+100°C)	-40...+302°F (-40...+150°C)	E - Fluorinated liquid "E"	-40...+212°F (-40...+100°C)	-40...+302°F (-40...+150°C)
B - Silicon oil "B"	-40...+302°F (-40...+150°C)	-40...+482°F (-40...+250°C)	F - Silicon oil "C"	-130...+176°F (-90...+80°C)	-130...+302°F (-90...+150°C)
C - Silicon oil "C"	-14...+392°F (-10...+200°C)	-14...+662°F (-10...+350°C)	G - Mineral food oil "G"	-14...+302°F (-10...+150°C)	-14...+392°F (-10...+200°C)
D - Silicon oil "D"	-14...+392°F (-10...+200°C)	-14...+752°F (-10...+400°C)			

OPTIONS

C05 - Helium Test (1)	TS4 - Washing plug (1)
E30 - Nace version bMR0103 (2) - MR0175 (ISO 15156) (3)	

(1) available only on some executions: contact our Technical Department.

(2) Monel 400 or Hastelloy C diaphragm.

(3) Hastelloy C process connection and diaphragm.

back side diaphragm seals with flanged connection

MGS9/3B

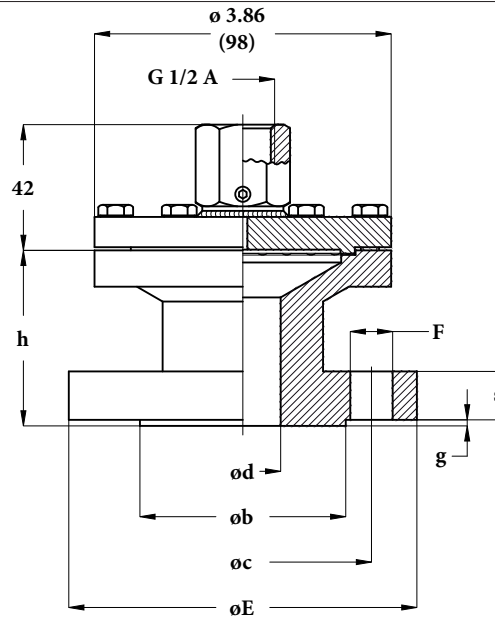

EN 1092 STANDARD

dimensions : mm

DN (1)	PN-bar	Code	h	E	b	d	g	c	s	F	N (2)
15	6	OO0	48	80	40	15	2	55	12	11	4
15	10÷16	OQ0	52	95	45	15	2	65	14	14	4
15	25÷40	OS0	52	95	45	15	2	65	14	14	4
25	6	QO0	50	100	60	25	2	75	14	11	4
25	10÷16	QO0	54	115	68	25	2	85	16	14	4
25	25÷40	QS0	54	115	68	25	2	85	16	14	4
50	6	TO0	54	140	90	50	2	110	16	14	4
50	10÷16	TQ0	61	165	102	50	2	125	19	18	4
50	25÷40	TS0	62	165	102	50	2	125	20	18	4

1) DN 20, 40 and over are available

2) N°holes.

ASME STANDARDS

dimensions : inches

DN (1)	Classe	Code	h	E	b	d	g	c	s	F	N (2)
1/2"	150	4AA	1.89"	3.54"	1.37"	0.59"	0.08"	2.37"	0.38"	0.63"	4
1/2"	300	4BA	2.11"	3.74"	1.37"	0.59"	0.08"	2.62"	0.50"	0.63"	4
1/2"	600	4DA	2.37"	3.74"	1.37"	0.59"	0.27"	2.62"	0.56"	0.63"	4
1"	150	6AA	2.01"	4.33"	2"	0.98"	0.08"	3.12"	0.50"	0.63"	4
1"	300	6BA	2.38"	4.88"	2"	0.98"	0.08"	3.5"	0.62"	0.75"	4
1"	600	6DA	2.64"	4.88"	2"	0.98"	0.27"	3.5"	0.69"	0.75"	4
2"	150	BAA	2.20"	6"	3.62"	1.96"	0.08"	4.75"	0.69"	0.75"	4
2"	300	BBA	2.37"	6.49"	3.62"	1.96"	0.08"	5"	0.81"	0.75"	8
2"	600	BDA	2.75"	6.49"	3.62"	1.96"	0.27"	5"	1"	0.75"	8

1) 3/4", 1"1/2 and over are available

2) N°holes.

"HOW TO ORDER" SEQUENCE

Section	Model / material	Connection / material	Diaphragm	Process / connection	Flange / finishing	Instrument / connection	Assembling	Options
4	3B0	4, 5, N	4, 6, 9 B, 2, 8	OO0...TS0 4AA...BDA	RF3...RF8	41F - G 1/2 F	D 1, 9, 6	B...G C05...E30

Copyright © Nuova Fima srl. All rights reserved. Any part of this publication should not be reproduced without a written Nuova Fima's srl approval

back side diaphragm seals, with flanged connection

Diaphragm seals are designed to isolate the sensing element of pressure gauges, pressure switches and electronic pressure transmitter from process fluids which may be corrosive, viscous, sedimentous and/or with a high temperature. The diaphragm is leak proof tested to guarantee fill fluid separation from process fluid. Process side are ASME/EN 1092 flanged to suit application in chemical, petrochemical, water treatment and paper industries.



4.600 - MGS9/6

Instrument type	Minimum range	Maximum range	Notes
Bourdon tube, DS 4", 6" (100...150 mm)	0...10 psi (0...0,6 bar)	0...580 psi (0...40 bar)	Vacuum and compound gauges included
Diaphragm differential pressure gauges	0...100 InH ₂ O (0...250 mbar)	0...360 psi (0...25 bar)	Max static pressure 60 bar
Diaphragm pressure switches	0...15 psi (0...15 bar)	0...580 psi (0...40 bar)	Vacuum and compound gauges included
Pressure transmitters	0...40 InH ₂ O (0...100 mbar)	0...580 psi (0...40 bar)	Max static pressure 60 bar

Working temperature: -49...+302°F (-45°C...+150°C.)

Accuracy*: (add to instrument accuracy) ±0,5% for direct mounting; ± 1% for capillary mounting.

Instrument connection: AISI 316 st.st.

Diaphragm: AISI 316L st.st. (cod. **4**), Monel 400 (cod. **6**), Hastelloy C276 (cod. **9**), Tantalum (cod. **B**), Titanium (cod. **2**) and AISI 316L st.st. PTFE coated (cod. **8**)**.

Gaskets: PTFE (max. 250°C).

Flanged process connection: in AISI 316 st.st. (cod. **4**), AISI 316L st.st. (cod. **5**), AISI 316L st.st. PTFE coated (cod. **N**)**.

Dimensions: DN 15...50, PN 6...40 EN 1092 step seal; 1/2"...2" class 150...600 RF as per ASME B16.5.

* at +68°F (20 °C) process temperature (or state when ordering)

EN 1092 flanges finishing: type B1 (PN 2,5...40) = Ra 3,2...12,5 µm (cod. **RF7**); type B2 (PN 63...100) = Ra 0,8...3,2 µm (cod. **RF8**).

ASME flanges finishing: type RF = Ra 125...250 AARH (cod. **RF3**).

Filling liquid: silicon oil.

Studs, nuts: AISI 304 st.st.

** max. temperature 328°F (150 °C), with PTFE coating.

ASSEMBLING

All diaphragm seals are mounted on the instruments and fixed by an aluminium protection label. For applications with capillary: should diaphragm seal and instrument not be at the same level, instrument adjustment is required). (For use and installation, see data sheet "4")

D - Direct	9 - Capillary AISI304 st.st., AISI304 st.st. armoured, 36.37" max (6 mt max)
1 - Nude capillary AISI304, 36.37" max (6 mt max)	6 - Capillary AISI316 st.st., AISI316 st.st. armoured, 36.37" max (6 mt max)

FILLING FLUIDS and process fluid temperature

Fluid	Vacuum	Pressure	Fluid	Vacuum	Pressure
Standard silicon oil	-40...+122°F (-40...+100°C)	-40...+302°F (-40...+150°C)	E - Fluorinated liquid "E"	-40...+212°F (-40...+100°C)	-40...+302°F (-40...+150°C)
B - Silicon oil "B"	-40...+302°F (-40...+150°C)	-40...+482°F (-40...+250°C)	F - Silicon oil "C"	-130...+176°F (-90...+80°C)	-130...+302°F (-90...+150°C)
C - Silicon oil "C"	-14...+392°F (-10...+200°C)	-14...+662°F (-10...+350°C)	G - Mineral food oil "G"	-14...+302°F (-10...+150°C)	-14...+392°F (-10...+200°C)
D - Silicon oil "D"	-14...+392°F (-10...+200°C)	-14...+752°F (-10...+400°C)			

OPTIONS

C05 - Helium Test (1)	P15 - Studs, nuts and washers
E30 - Nace version bMR0103 (2) - MR0175 (ISO 15156) (3)	TS4 - Washing plug (1)

(1) available only on some executions: contact our Technical Department.

(2) Monel 400 or Hastelloy C diaphragm.

(3) Hastelloy C process connection and diaphragm.

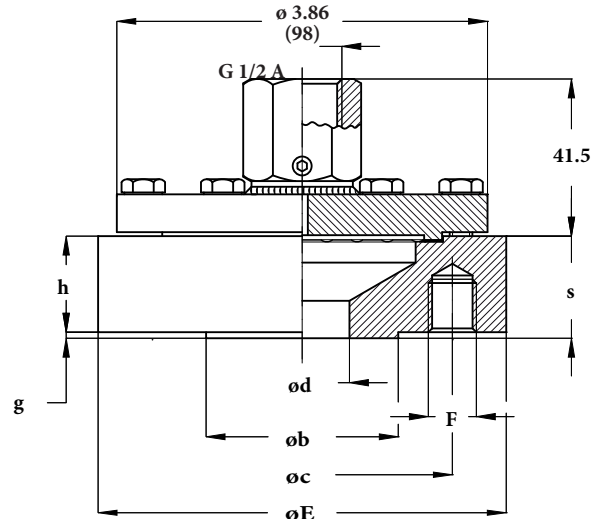

EN 1092 STANDARD

dimensions : mm

DN (1)	PN	Code	E	h	b	d	g	c	s	F	N (1)
15	10...16	OQ0	95	24,5	45	15	2	65	26,5	M12	4
	25...40	OS0									
20	10...16	PQ0	105	22,5	58	20	2	75	24,5	M12	4
	25...40	PS0									
25	10...16	QQ0	115	20,5	68	25	2	85	22,5	M12	4
	25...40	QS0									
40	10...16	SQ0	150	18	88	40	3	110	21	M16	4
	25...40	SS0									
50	10...16	TQ0	165	18	102	50	3	125	21	M16	4
	25...40	TS0									

1) DN20 and over DN50 are available

2) N° holes

ASME STANDARDS

dimensions : inches

DN (1)	Class	Code	h	E	b	d	g	c	s	N (1)	F
1/2"	150	4AA	1.06"	3.54"	1.37"	0.59"	0.08"	2.37"	1.14"	4	1/2"-13UNC
1/2"	300	4BA	1"	3.74"	1.37"	0.59"	0.08"	2.63"	1.08"	4	1/2"-13UNC
1/2"	600	4DA	1"	3.74"	1.37"	0.59"	0.27"	2.63"	1.28"	4	1/2"-13UNC
3/4"	150	5AA	0.98"	3.94"	1.69"	0.79"	0.08"	2.75"	1.14"	4	1/2"-13UNC
3/4"	300	5BA	1.34"	4.53"	1.69"	0.79"	0.08"	2.63"	1.06"	4	5/8"-11UNC
3/4"	600	5DA	1.34"	4.53"	1.69"	0.79"	0.27"	3.25"	1.61"	4	5/8"-11UNC
1"	150	6AA	0.9"	4.33"	2"	0.98"	0.08"	3.25"	0.98"	4	1/2"-13UNC
1"	300	6BA	1.34"	4.92"	2"	0.98"	0.08"	3.5"	1.42"	4	5/8"-11UNC
1"	600	6DA	1.34"	4.92"	2"	0.98"	0.27"	3.5"	1.61"	4	5/8"-11UNC
1 1/2"	150	AAA	0.69"	4.92"	2.87"	1.57"	0.08"	3.87"	0.77"	4	1/2"-13UNC
1 1/2"	300	ABA	0.83"	6.1"	2.87"	1.57"	0.08"	4.5"	0.9"	4	3/4"-10UNC
1 1/2"	600	ADA	0.88"	6.1"	2.87"	1.57"	0.27"	4.5"	1.17"	4	3/4"-10UNC
2"	150	BAA	0.69"	5.9"	3.63"	1.97"	0.08"	4.75"	0.77"	4	5/8"-11UNC
2"	300	BBA	0.81"	6.5"	3.63"	1.97"	0.08"	5"	0.89"	8	5/8"-11UNC
2"	600	BDA	1"	6.5"	3.63"	1.97"	0.27"	5"	1.28"	8	5/8"-11UNC

1) 3/4" is available

2) Nr. holes

"HOW TO ORDER" SEQUENCE

Section / Model / Connection / Diaphragm / Process / Flange / Instrument / Assembling / Options	material	material	material	connection	finishing	connection	connection	connection	Options
4	600	4, 5, N	4, 6, 9 B, 2, 8	OOO...TS0 4AA...BDA	RF3...RF8	41F - G 1/2 F	D 1, 9, 6	B...G C05...TS4	

“continuous duty” diaphragm seal, welded, with flanged connection



Diaphragm seals are designed to isolate the sensing element of pressure gauges, pressure switches and electronic pressure transmitter from process fluids which may be corrosive, viscous, sedimentous and/or with a high temperature. “Continuous duty” version as per ASME B40.2 : in case of accidental removal of the instrument or of liquid filling leak the diaphragm will place on the upper cup preventing any damage and any process liquid leak. Thanks to an exclusive calibration system the pressure gauge should stand an overpressure of 210 bar without the help of any pressure control switch. Process side are ASME/EN 1092 flanged to suit application in chemical, petrochemical, water treatment and paper industries.

4.700 - MGS9/7

Pressure gauge ranges: from -30...0 INHG to 0...2320 psi (from -1...0 to 0...160 bar) ⁽¹⁾.

Filling liquid: silicon oil (see “Options” table).

Process fluid max temperature: as per filling liquid (see “Options” table).

Accuracy: (add to instrument accuracy) ±0,5% for direct mounting; ± 1% for capillary mounting ⁽²⁾.

Instrument connection: AISI 304 st.st.

Membrana saldata in: AISI 316L st.st. (code **4**), Monel 400 (code **6**), Hastelloy C276 (code **9**), Tantalum (code **B**), Alloy 600 (code **J**), Alloy 825 (code **I**), 25.22.2 (code **U**).

Gasket: PTFE (max. +482°F; +250°C);

Flanged process connection: AISI 316L st.st (cod. **4**), AISI 316L st.st (cod. **5**), Monel 400 (cod. **6**), Hastelloy C276 (cod. **9**), Hastelloy B2 (cod. **1**); other materials available on request.

Dimensions ⁽³⁾: DN 15...50, PN 10...160 EN 1092-1 type B; 1/2”...2” class 150...1500 RF as per ASME B16.5.

Finishing: EN B1 type: Ra 3,2...12,5 ASME RF type: Ra 125...250 AARH (code **RF3**).

Bolts: AISI304 st.st., for flange PN ≤ 100 or class ≤ 600; high resistance steel for flange PN > 100 or class > 600.

(1) Working pressure must be less or equal to the flange rating

(2) at 68°F (20 °C) process temperature (or state temperature when ordering)

(3) other dimensions and finishing are available on request

ASSEMBLING

All diaphragm seals are mounted on the instruments and fixed by an aluminium protection label. For applications with capillary: should diaphragm seal and instrument not be at the same level, instrument adjustment is required). (For use and installation, see data sheet “4”)

D - Direct	9 - Capillary AISI304 st.st., AISI304 st.st. armoured, 36.37” max (6 mt max)
1 - Nude capillary AISI304, 36.37” max (6 mt max)	6 - Capillary AISI316 st.st., AISI316 st.st. armoured, 36.37” max (6 mt max)

FILLING FLUIDS and process fluid temperature

Fluid	Vacuum	Pressure	Fluid	Vacuum	Pressure
Standard silicon oil	-40...+122°F (-40...+100°C)	-40...+302°F (-40...+150°C)	E - Fluorinated liquid “E”	-40...+212°F (-40...+100°C)	-40...+302°F (-40...+150°C)
B - Silicon oil “B”	-40...+302°F (-40...+150°C)	-40...+482°F (-40...+250°C)	F - Silicon oil “C”	-130...+176°F (-90...+80°C)	-130...+302°F (-90...+150°C)
C - Silicon oil “C”	-14...+392°F (-10...+200°C)	-14...+662°F (-10...+350°C)	G - Mineral food oil “G”	-14...+302°F (-10...+150°C)	-14...+392°F (-10...+200°C)
D - Silicon oil “D”	-14...+392°F (-10...+200°C)	-14...+752°F (-10...+400°C)			

OPTIONS

C05 - Helium Test	S40 - Special calibration for pressure gauges overpressure ^{(3) (4) (5)}
E30 - Nace version MR0103/MR0175 (ISO 15156) ⁽²⁾	MPP - PTFE diaphragm protection, for temperature up to 302 °F (150 °C) ⁽³⁾
TSS - AISI316L stainless steel washing plug, 1/4” NPT ⁽¹⁾	P15 - ASTM A193/B7 - A194/2H studs, nuts and washers
P04 - Dye penetrant test	

(1) on models with AISI316L process connection only

(2) Stainless steel process connection and Monel 400 or Hastelloy C276 diaphragm

(3) Except for vacuum and compound gauges

(4) Overpressure equal to flange rating, max 3000 psi (210 bar)

(5) To be ordered with silicon oil “B” only

**"continuous duty" diaphragm seal
welded, with flanged connection**

MGS9/7

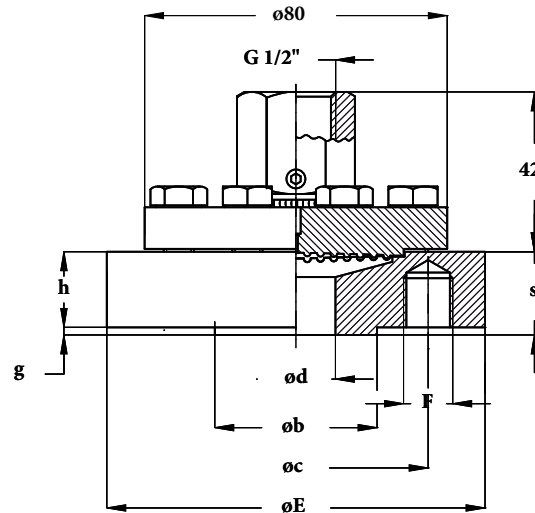

EN 1092-1:2007 STANDARD

dimensions : mm

DN	PN-bar	Code	h	E	b	d	g	c	s	N (1)	F
15	10-16-25-40	OSO	20	95	45	15	2	65	22	4	M12
15	63...160	OZO	18	105	45	15	2	75	20	4	M12
20	10-16-25-40	PSO	16	105	58	20	2	75	18	4	M12
20	63...100	PUO	20	130	58	20	2	90	22	4	M16
25	10-16-25-40	QSO	16	115	68	25	2	85	18	4	M12
25	63...160	QZO	22	140	68	25	2	100	24	4	M16
40	10-16-25-40	SSO	18	150	88	40	3	110	21	4	M16
40	63...100	SUO	23	170	88	40	3	125	26	4	ø22
40	160	SZO	25	170	88	40	3	125	28	4	ø22
50	10-16-25-40	TSO	17	165	102	50	3	125	20	4	ø18
50	63	TTO	23	180	102	50	3	135	26	4	ø22
50	100	TUO	25	195	102	50	3	145	28	4	ø26
50	160	TZO	27	195	102	50	3	145	30	4	ø26

1) N° threaded or free holes

ASME B16-5:2003 STANDARD

dimensions : inches

DN	Classe (2)	Code	h	E	b	d	g	c	s	N (1)	F
1/2"	150	4AA	0.87"	3.54"	1.37"	0.59"	0.08"	2.37"	0.94"	4	1/2"-13UNC
1/2"	300	4BA	0.81"	3.74"	1.37"	0.59"	0.08"	2.63"	0.89"	4	1/2"-13UNC
1/2"	600	4DA	0.81"	3.74"	1.37"	0.59"	0.28"	2.63"	1.08"	4	1/2"-13UNC
1/2"	900...1500	4FA	0.89"	4.72"	1.61"	0.59"	0.28"	3.25"	1.16"	4	3/4"-10UNC
3/4"	150	5AA	0.79"	3.94"	1.69"	0.79"	0.08"	2.75"	0.87"	4	1/2"-13UNC
3/4"	300	5BA	0.71"	4.53"	1.69"	0.79"	0.08"	3.25"	0.79"	4	5/8"-11UNC
3/4"	600	5DA	0.71"	4.53"	1.69"	0.79"	0.28"	3.25"	0.98"	4	5/8"-11UNC
3/4"	900...1500	5FA	1"	5.12"	1.69"	0.79"	0.28"	3.5"	1.30"	4	3/4"-10UNC
1"	150	6AA	0.63"	4.33"	2"	0.98"	0.08"	3.13"	0.71"	4	1/2"-13UNC
1"	300	6BA	0.71"	4.92"	2"	0.98"	0.08"	3.5"	0.79"	4	5/8"-11UNC
1"	600	6DA	0.71"	4.92"	2"	0.98"	0.28"	3.5"	0.98"	4	5/8"-11UNC
1"	900...1500	6FA	1.14"	5.9"	2"	0.98"	0.28"	4"	1.42"	4	7/8"-9UNC
1 1/2"	150	AAA	0.63"	4.92"	2.87"	1.57"	0.08"	3.87"	0.71"	4	1/2"-13UNC
1 1/2"	300	ABA	0.81"	6.1"	2.87"	1.57"	0.08"	4.5"	0.89"	4	3/4"-10UNC
1 1/2"	600	ADA	0.89"	6.1"	2.87"	1.57"	0.28"	4.5"	1.16"	4	3/4"-10UNC
1 1/2"	900...1500	AFA	1.26"	7.09"	2.87"	1.57"	0.28"	4.87"	1.56"	4	1"-8UNC
2"	150	BAA	0.69"	5.9"	3.63"	1.97"	0.08"	4.75"	0.77"	4	ø 19
2"	300	BBA	0.83"	6.5"	3.63"	1.97"	0.08"	5"	0.91"	8	ø 19
2"	600	BDA	1"	6.5"	3.63"	1.97"	0.28"	5"	1.28"	8	ø 19
2"	900...1500	BFA	1.52"	8.46"	3.63"	1.97"	0.28"	6.51"	1.79"	8	ø 26

1) N° threaded or free holes

2) class 150 : PN 20 bar; class 300 : PN 50 bar; class 600 : PN 100 bar; class 900...1500 : PN 150...250 bar

"HOW TO ORDER" SEQUENCE

Section / Model / Connection / Diaphragm / Process / Flange / Instrument / Assembling / Options	material	material	connection	connection		finishing	connection		
4	700	4, 5, 6 9, 1	4, 6, 9 B, J, I U	OS0...TZ0 4AA...BFA		RF3...RF7	41F	D 1, 9, 6	B...G C05...P15

Copyright © Nuova Fima srl. All rights reserved. Any part of this publication should not be reproduced without a written Nuova Fima's srl approval



RC2 -08/14 IN ORDER TO IMPROVE THEIR PRODUCTION, MESSIS, NUOVA FIMA RESERVE THE RIGHT TO THEMSELVES TO MAKE ALL THE MODIFICATIONS THAT THEY DEEM INDISPENSABLE AT ANY TIME. UPDATED DATA-SHEETS ARE AVAILABLE ON SITE: www.nuovafima.com

"In line" diaphragm seal, with flanged connection



Diaphragm seals are designed to isolate the sensing element of pressure gauges, pressure switches and electronic pressure transmitters from process liquids which may be corrosive, viscous, sedimentous and/or with a high temperature. The diaphragm welded to the upper body and leak proof tested, ensure separation of filling fluid from process medium. Diaphragm position permit an accurate and deeper cleaning. Process sizes are ASME/UNI/DIN flanged to suit application in chemical, petrochemical, water treatment and paper industries.

4.400 - MGS9/4

Working pressure: from 0...15 to 0...600 psi (from 0...1 to 0...40 bar).

Working temperature: -49...+302°F (-45°C...+150°C.)

Accuracy*: (add to instrument accuracy) ±0,5% for direct mounting; ± 1% for capillary mounting.

Instrument connection: AISI 316 st.st.

Diaphragm: AISI 316L st.st (cod. **4**), Monel 400 (cod. **6**), Hastelloy C276 (cod. **9**), Hastelloy B2 (cod. **1**), Tantalum (cod. **B**), Titanium (cod. **2**), Nickel (cod. **7**), AISI 316 L st.st. PTFE coated** (cod. **8**), Incoloy 825 (cod. **I**), Inconel 600 (cod. **J**).

Flanged process connection: AISI 316 st.st. (cod. **4**), AISI316 L st.st. (cod. **5**), Monel 400 (cod. **6**), Hastelloy C276 (cod. **9**), Hastelloy B2 (cod. **1**), Tantalum (cod. **B**), Titanium (cod. **2**), Nickel (cod. **7**), AISI

* at +68°F (20 °C) process temperature (or state when ordering)

316 st.st. PTFE** coated (cod. **N**), ASTM A182 gr. F51 (cod. **S**).

Dimensions : DN 15...50 e PN 10...40 UNI-DIN step seal; 1/2"...2" class 150...600 RF as per ASME B16.5.

UNI-DIN flanges finishing: type B1 (PN 2,5...40) = Ra 3,2...12,5 µm (cod. **RF7**); type B2 (PN 63...100) = Ra 0,8...3,2 µm (cod. **RF8**).

ASME flanges finishing: type RF = Ra 125...250 AARH (cod. **RF3**).

Filling liquid: silicon oil.

** max. temperature 328°F (150 °C), with PTFE coating.

ASSEMBLING

All diaphragm seals are mounted on the instruments and fixed by an aluminium protection label. For applications with capillary: should diaphragm seal and instrument not be at the same level, instrument adjustment is required). (For use and installation, see data sheet "4")

D - Direct	9 - Capillary AISI304 st.st., AISI304 st.st. armoured, 36.37" max (6 mt max)
I - Nude capillary AISI304, 36.37" max (6 mt max)	6 - Capillary AISI316 st.st., AISI316 st.st. armoured, 36.37" max (6 mt max)

FILLING FLUIDS and process fluid temperature

Fluid	Vacuum	Pressure	Fluid	Vacuum	Pressure
Standard silicon oil	-40...+122°F (-40...+100°C)	-40...+302°F (-40...+150°C)	E - Fluorinated liquid "E"	-40...+212°F (-40...+100°C)	-40...+302°F (-40...+150°C)
B - Silicon oil "B"	-40...+302°F (-40...+150°C)	-40...+482°F (-40...+250°C)	F - Silicon oil "C"	-130...+176°F (-90...+80°C)	-130...+302°F (-90...+150°C)
C - Silicon oil "C"	-14...+392°F (-10...+200°C)	-14...+662°F (-10...+350°C)	G - Mineral food oil "G"	-14...+302°F (-10...+150°C)	-14...+392°F (-10...+200°C)
D - Silicon oil "D"	-14...+392°F (-10...+200°C)	-14...+752°F (-10...+400°C)			

OPTIONS

C05 - Helium Test (1)	P04 - Dye penetrant test (1)
E30 - NACE MR0103/MR0175 (ISO 15156) (2)	

(1) Available for some excutions pls. consult our technical dep. to check their feasibility.

(2) With Monel 400 or Hastelloy C diaphragm only.

"In line" diaphragm seal, with flanged connection

MGS9/4

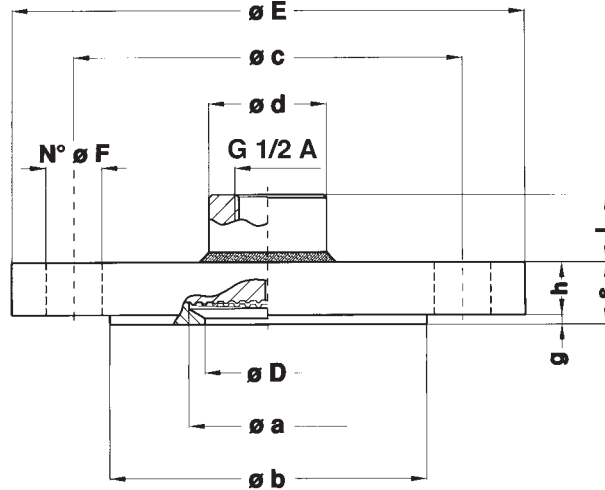

UNI-DIN STANDARDS

dimensions : mm

DN	PN-bar	Code	D	E	c	b	a	d	g	h	s	L	N (1)	F	Ranges (2)
15	10...40	OK0	15	95	65	45	40	28	2	17	19	16,5	4	14	2,5...40
20	10...40	PK0	20	105	75	58	40	28	2	17	19	16,5	4	14	2,5...40
25	10...40	QK0	25	115	85	68	50	38	2	17	19	24,5	4	14	1...40
40	10...40	SK0	40	150	110	88	50	38	3	16	19	24,5	4	18	1...40
50	10...40	TK0	50	165	125	102	50	38	3	17	20	23,5	4	18	1...40

(1) N° holes .

(2) bar ranges, for instruments with dial size $\geq 4''$ (100mm).

ASME STANDARDS

dimensions : inches

DN	Class	Code	D	E	c	b	a	d	g	h	s	L	N (1)	F	Ranges (3)
1/2"	150	4AA	0.59"	3.5"	2.37"	1.37"	1.18"	1.02"	0.06"	0.66"	0.72"	0.64"	4	0.62"	100...290 (4)
1/2"	300	4BA	0.59"	3.74"	2.62"	1.37"	1.18"	1.02"	0.06"	0.66"	0.72"	0.64"	4	0.62"	100...580
1/2"	600	4DA	0.59"	3.74"	2.62"	1.37"	1.18"	1.02"	0.25"	0.66"	0.95"	0.64"	4	0.62"	100...580
3/4"	150	5AA	0.78"	3.87"	2.74"	1.68"	1.57"	1.10"	0.06"	0.66"	0.72"	0.64"	4	0.62"	60...290
3/4"	300	5BA	0.78"	4.62"	3.24"	1.68"	1.57"	1.10"	0.06"	0.66"	0.72"	0.64"	4	0.74"	60...580
3/4"	600	5DA	0.78"	4.62"	3.24"	1.68"	1.57"	1.10"	0.25"	0.66"	0.95"	0.64"	4	0.74"	60...580
1"	150	6AA	0.98"	4.25"	3.12"	2"	1.57"	1.10"	0.06"	0.7"	0.76"	0.64"	4	0.62"	60...290
1"	300	6BA	0.98"	4.88"	3.5"	2"	1.96"	1.49"	0.06"	0.7"	0.76"	0.96"	4	0.74"	15...580
1"	600	6DA	0.98"	4.88"	3.5"	2"	1.96"	1.49"	0.25"	0.7"	0.96"	0.96"	4	0.74"	15...580
1 1/2"	150	AAA	1.57"	5"	3.87"	2.87"	1.96"	1.49"	0.06"	0.7"	0.76"	0.96"	4	0.62"	15...290
1 1/2"	300	ABA	1.57"	6.12"	4.5"	2.87"	1.96"	1.49"	0.06"	0.80"	0.86"	0.86"	4	0.86"	15...580
1 1/2"	600	ADA	1.57"	6.12"	4.5"	2.87"	1.96"	1.49"	0.25"	0.88"	1.14"	0.59"	4	0.86"	15...580
2"	150	BAA	1.96"	6"	4.74"	3.62"	1.96"	1.49"	0.06"	0.74"	0.80"	0.92"	4	0.74"	15...290
2"	300	BBA	1.96"	6.49"	5"	3.62"	1.96"	1.49"	0.06"	0.88"	0.94"	0.78"	8	0.74"	15...580
2"	600	BDA	1.96"	6.49"	5"	3.62"	1.96"	1.49"	0.25"	1.04"	1.25"	0.47"	8	0.74"	15...580

(1) N° holes .

(2) bar ranges, for instruments with dial size $\geq 4''$ (100mm).

(3) psi ranges, for instruments with dial size $\geq 4''$ (100mm).

(4) not available, when PTFE coated.

"HOW TO ORDER" SEQUENCE

Section	Model	Connection material	Diaphragm connection	Process	Flange finishing	Instrument connection	Assembling	Options
4	400	4, 5, 6 9, 1, B 2, 7, N, S	4, 6, 9 1, B, 2 7, 8, I, J	OK0..TK0 4AA...BDA	RF3...RF8	41F - G 1/2 F	D 1, 9, 6	B...G C04...P04

Copyright © Nuova Fima srl. All rights reserved. Any part of this publication should not be reproduced without a written Nuova Fima's srl approval

NUOVA FIMA USA Inc.
www.nuovafima.com - e-mail: infousa@nuovafima.com
4123 Hollister, Suite G - TX 77080 Houston
TEL. +1 713.690.9800 - FAX +1 713.690.9803

-2-

NUOVA FIMA srl
www.nuovafima.com - e-mail: info@nuovafima.com
P.O. BOX 58 - VIA C. BATTISTI 59 - 28045 INVORIO (NO) ITALY
TEL. +39 0322 253200 - FAX +39 0322 253232



RCF-08/4

IN ORDER TO IMPROVE THEIR PRODUCTION, MESSRS. NUOVA FIMA RESERVE THE RIGHT TO THEMSELVES TO MAKE ALL THE MODIFICATIONS THAT THEY DEEM INDISPENSABLE AT ANY TIME. UPDATED DATA SHEETS ARE AVAILABLE ON SITE: www.nuovafima.com

diaphragm seals, welded



Diaphragm seals are designed to isolate the sensing element of pressure gauges and pressure switches from process fluids which may be corrosive, viscous, sedimentous and/or with a high temperature. The diaphragm is welded to the upper body, to ensure separation of filling fluid from process medium. Diaphragm faced position permit an accurate and deeper cleaning. Process sizes are ASME/EN 1092 flanged to suit application in chemical, petrochemical, water treatment, paper industries.

4.500 - MGS9/5

Nominal pressure: up to 0...6000 psi (up to 0...400 bar) depending on flange rating.

Measuring ranges: from -30...0 IN Hg to 0...6000 psi (from -1...0 to 0...400 bar); see also table at page 2.

Working temperature: -130...+752°F (-90°C...+400°C.); depending on filling fluid.

Accuracy*: (add to instrument accuracy) ±0,5% for direct mounting; ± 1% for capillary mounting.

Diaphragm, welded to process connection:

AISI 316 L st.st (cod. **4**); Monel 400 (cod. **6**); Hastelloy C 276 (cod. **9**).

Flanged process connection: AISI 316 st.s. (cod. **4**); AISI 316L st.s. (cod. **5**).

* at +68°F (20 °C) working temperature

Full-cover version: wetted parts covered with

Monel 400 (cod. **6FC**); Hastelloy C 276 (cod. **9FC**); Tantalum (cod. **BFC**).

Dimensions : DN 25...100 and PN 2,5...400 EN 1092-1; 1" ...4" class 150...2500 as per ASME B16.5.

Finishing: EN 1092-1 type B: Ra 3,2...12,5 µm (cod. **RF7**); ASME B16.5 type RF = Ra 125...250 AARH (cod. **RF3**); (all other finishing type are available).

ASSEMBLING

All diaphragm seals are mounted on the instruments and fixed by an aluminium protection label. For applications with capillary: should diaphragm seal and instrument not be at the same level, instrument adjustment is required). (For use and installation, see data sheet "4")

D - Direct	9 - Capillary AISI304 st.st., AISI304 st.st. armoured, 36.37" max (6 mt max)
1 - Nude capillary AISI304, 36.37" max (6 mt max)	6 - Capillary AISI316 st.st., AISI316 st.st. armoured, 36.37" max (6 mt max)

FILLING FLUIDS and process fluid temperature

Fluid	Vacuum	Pressure	Fluid	Vacuum	Pressure
Standard silicon oil	-40...+122°F (-40...+100°C)	-40...+302°F (-40...+150°C)	E - Fluorinated liquid "E"	-40...+212°F (-40...+100°C)	-40...+302°F (-40...+150°C)
B - Silicon oil "B"	-40...+302°F (-40...+150°C)	-40...+482°F (-40...+250°C)	F - Silicon oil "F"	-130...+176°F (-90...+80°C)	-130...+302°F (-90...+150°C)
C - Silicon oil "C"	-14...+392°F (-10...+200°C)	-14...+662°F (-10...+350°C)	G - Mineral food oil "G"	-14...+302°F (-10...+150°C)	-14...+392°F (-10...+200°C)
D - Silicon oil "D"	-14...+392°F (-10...+200°C)	-14...+752°F (-10...+400°C)			

OPTIONS

C05 - Helium Test (1)	P04 - Dye penetrant test (1)
E30 - NACE MR0103/MR0175 (ISO 15156) (2)	

(1) Available for some excutions pls. consult our technical dep. to check their feasibility.

(2) With Monel 400 or Hastelloy C diaphragm only.

MINIMUM MEASURING RANGES (bar)
dimensions : mm

φ M	30	40	50	65
pressure	6	2,5	1	0,6
vacuum			-1	-1
vacuum...pressure	-1...+5	-1...+1,5	-1...+0,6	-1...+0,6

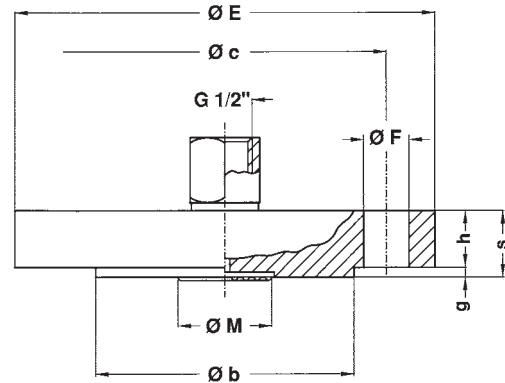

EN 1092 STANDARD, type B
dimensions : mm

DN (1)	PN-bar (1) (3)	Code	E	c	b	g	h	s	N (2)	F	M
25	10...16/25...40	QQ0/QS0	115	85	68	2	16	18	4	14	30
25	63/100	QT0/QU0	140	100	68	2	22	24	4	18	30
40	10...16/25...40	SQ0/SS0	150	110	88	3	15	18	4	18	40
40	63/100	ST0/SU0	170	125	88	3	23	26	4	22	40
50	10...16	TQ0	165	125	102	3	15	18	4	18	50
50	25...40	TS0	165	125	102	3	17	20	4	18	50
50	63	TT0	180	135	102	3	23	26	4	22	50
50	100	TU0	195	145	102	3	25	28	4	26	50
80	10/16	VP0/VQ0	200	160	138	3	17	20	8	18	65
80	25...40	VS0	200	160	138	3	21	24	8	18	65
80	100	VU0	230	180	138	3	29	32	8	26	65

(1) Flanges DN 25...100 and PN 2.5...400 are all available

(3) Maximum nominal pressure of connected instrument

(2) N° holes.

ASME B16.5 STANDARD, type RF
dimensions : inches

DN (1)	Class (1)	bar (3)	Code	E	c	b	g	h	s	N (2)	F	M
1"	150	20	6AA	4,33"	3,13"	2"	0,08"	0,50"	0,58"	4	0,63"	1,18"
1"	300	50	6BA	4,92"	3,5"	2"	0,08"	0,63"	0,7"	4	0,75"	1,18"
1"	600	110	6DA	4,92"	3,5"	2"	0,28"	0,69"	0,96"	4	0,75"	1,18"
1"	900...1500	150...260	6FA	5,91"	4"	2"	0,28"	1,13"	1,4"	4	1"	1,18"
1" 1/2	150	20	AAA	4,92"	3,87"	2,87"	0,08"	0,63"	0,7"	4	0,63"	1,57"
1" 1/2	300	50	ABA	6,1"	4,5"	2,87"	0,08"	0,75"	0,83"	4	0,87"	1,57"
1" 1/2	600	110	ADA	6,1"	4,5"	2,87"	0,28"	0,88"	1,15"	4	0,87"	1,57"
1" 1/2	900...1500	150...260	AFA	7,09"	4,87"	2,87"	0,28"	1,25"	1,53"	4	1,12"	1,57"
1" 1/2	2500	420	AGA	8,07"	5,75"	2,87"	0,28"	1,75"	2,03"	4	1,26"	1,57"
2"	150	20	BAA	5,91"	4,75"	3,63"	0,08"	0,69"	0,77"	4	0,75"	1,97"
2"	300	50	BBA	6,5"	5"	3,63"	0,08"	0,81"	0,89"	8	0,75"	1,97"
2"	600	110	BDA	6,5"	5"	3,63"	0,28"	1"	1,28"	8	0,75"	1,97"
2"	900...1500	150...260	BFA	8,46"	6,5"	3,63"	0,28"	1,5"	1,78"	8	1"	1,97"
2"	2500	420	BGA	9,25"	6,75"	3,63"	0,28"	2"	2,28"	8	1,12"	1,97"
3"	150	20	EAA	7,48"	6"	5"	0,08"	0,88"	0,96"	4	0,75"	2,56"
3"	300	50	EBA	8,27"	6,63"	5"	0,08"	1,06"	1,14"	8	0,87"	2,56"
3"	600	110	EDA	8,27"	6,63"	5"	0,28"	1,25"	1,53"	8	0,87"	2,56"
3"	900	150	EFA	9,45"	7,5"	5"	0,28"	1,5"	1,78"	8	1"	2,56"
3"	1500	260	EFA	10,43"	8"	5"	0,28"	1,88"	2,15"	8	1,26"	2,56"

(1) Flanges 1"...4" and classes 150...2500 are all available.

(3) Maximum nominal pressure of connected instrument

(2) N° holes.

"HOW TO ORDER" SEQUENCE

Section	Model	Connection material	Diaphragm material	Process connection	Flange finishing	Instrument connection	Assembling	Options
4	500	4, 5	4, 5, 9 6FC...BFC	QQ0...VU0 6AA...EFA	RF3...RF7	41F - G 1/2 F	D, 1 9, 6	B...G C05...P04

"wafer" diaphragm seal



Diaphragm seals are designed to isolate the sensing element of pressure gauges, pressure switches and electronic pressure transmitters from process liquids which may be corrosive, viscous, sedimentous and/or with a high temperature. The diaphragm welded to the upper body and leak proof tested, ensure separation of filling fluid from process medium. Diaphragm faced position permit an accurate and deeper cleaning. Process sizes are ASME - EN 1092 flanged to suit application in chemical, petrochemical, water treatment, paper.

4.WAF - MGS9/WAFER

Working pressure: *from 0...40 INWC to 0...2000 psi* (da 0...100 mbar a 0...160 bar), depending on flange type.

Process temperature: *-49...+302°F* (-45°C...+150°C.)

Instrument connection: AISI 304 st.st. capillary, to be welded on the transmitter.

Diaphragm: AISI 316L st.st. (cod. **4**), Hastelloy C276 (cod. **9**), Hastelloy B2 (cod. **1**), Tantalum (cod. **B**).

Process connection: AISI 316 st.st. (cod. **4**), AISI 316L st.st. (cod. **5**), Hastelloy C276 (cod. **9**).

AISI 316 st.st flanged connection:

-ASME B16.5 standards: 2" - 3"; class 150...2500 form RF; -EN 1092 standard: DN 50 - 80 ; PN 16...160 step seal.

EN 1092 flanges finishing: type B1 (PN 2,5...40) = Ra 3,2...12,5 µm (cod. **RF7**); type B2 (PN 63...100) = Ra 0,8...3,2 µm (cod. **RF8**).

ASME flanges finishing: type RF = Ra 125...250 AARH (cod. **RF3**).

Filling liquid: silicon oil.

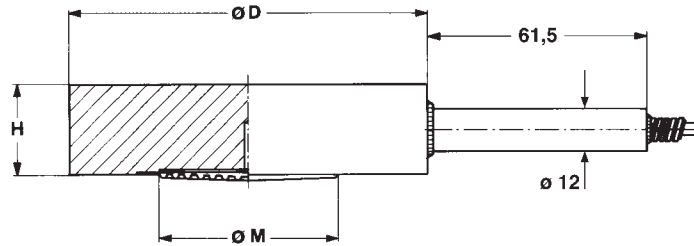

FLANGED CONNECTION AS PER EN 1092

DN	PN-bar	Code	D	M	H
50	16...160	TX0	4.01" (102)	1.96" (50)	0.78" (20)
80	16...160	VX0	5.43" (138)	2.55" (65)	

dimensions : inches (mm)

FLANGED CONNECTION AS PER ASME B16.5

DN	Class	Code	D	M	H
2"	150...2500	BJA	3,62"	1,96"	0,78"
3"	150...2500	EJA	5"	2,55"	0,78"

dimensions : inches

ASSEMBLING

Should diaphragm seal and instrument not be at a same level, instrument on installation is required.

1 - Capillary AISI304 st.st. 236" max (6 mt max)
9 - Capillary AISI304 st.st., AISI304 st.st. armoured, 236" max (6 mt max)
6 - Capillary AISI316 st.st., AISI316 st.st. armoured, 236" max (6 mt max)

FILLING FLUIDS and process fluid temperature

Fluid	Vacuum	Pressure	Fluid	Vacuum	Pressure
Standard silicon oil	-40...+122°F (-40...+100°C)	-40...+302°F (-40...+150°C)	E - Fluorinated liquid "E"	-40...+212°F (-40...+100°C)	-40...+302°F (-40...+150°C)
B - Silicon oil "B"	-40...+302°F (-40...+150°C)	-40...+482°F (-40...+250°C)	F - Silicon oil "C"	-130...+176°F (-90...+80°C)	-130...+302°F (-90...+150°C)
C - Silicon oil "C"	-14...+392°F (-10...+200°C)	-14...+662°F (-10...+350°C)	G - Mineral food oil "G"	-14...+302°F (-10...+150°C)	-14...+392°F (-10...+200°C)
D - Silicon oil "D"	-14...+392°F (-10...+200°C)	-14...+752°F (-10...+400°C)			

"HOW TO ORDER" SEQUENCE

Section	Model	Connection material	Diaphragm material	Process connection	Flange finishing	Instrument connection	Assembling	Options
4	WAF	4, 5, 9	4, 9 1, B	TX0...VX0 BJA...EJA	RF3 RF7 RF8	23M - 1/4 NPT M 41F - G 1/2 F	1, 9, 6	B...G

"in line" diaphragm seal



Diaphragm seals are designed to isolate the sensing element of pressure gauges and pressure switches from process fluids which may be corrosive, viscous, sedimentous and/or with a high temperature. The diaphragm is welded to the upper body, to ensure separation of filling fluid from process medium. The "in-line" diaphragm position enables deep cleaning of their surfaces. Flange clamping with metallic sealing guarantees the system against leakage at high process fluid temperatures and pressures.

4.R00 - MGS9/R

Working pressure: *from 0...100 to 0...3000 psi (from 0...6 to 0...250 bar).*

Process temperature: *-49...+302°F (-45°C...+150°C.)*

Accuracy*: (add to instrument accuracy) $\pm 0,5\%$ for direct mounting; $\pm 1\%$ for capillary mounting.

Instrument connection: AISI 316 st.st.

Bolts and lock ring: AISI 304 st.st.

Diaphragm: welded to process connection,

4 - AISI 316 L st.st,

9 - Hastelloy C276.

Process connection:

4 - AISI 316 st.st.,

5 - AISI 316L st.st.

Process connection, welded type:

7RC - saddle, for pipe size DN 2" ...4";

7MS - "in line", for pipe size 1/2" ...1";

7MT - "in line", for pipe size 1" 1/2...4".

Process connection, flanged type: (Mod. 7FL)

- "in line", for flange size 1" 1/2 - 2" ; 150...900 RF;

- "in line", for flange size DN 40...50, PN 10...100 step seal. **Filling**

liquid: silicon oil.

* at 68°F (20 °C) process temperature (or state temperature when ordering)

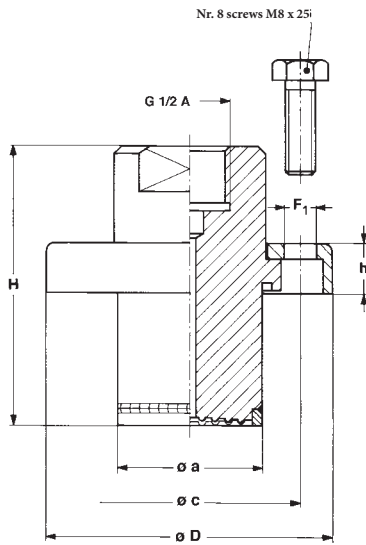

h	H	a	c	D	F ₁
0.51" (13)	2.91" (74)	1.49" (38)	2.28" (58)	2.95" (75)	0.33" (8,5)

dimensions : inches (mm)

ASSEMBLING

All diaphragm seals are mounted on the instruments and fixed by an aluminium protection label. For applications with capillary: should diaphragm seal and instrument not be at the same level, instrument adjustment is required). (For use and installation, see data sheet "4")

D - Direct	9 - Capillary AISI304 st.st., AISI304 st.st. armoured, 36.37" max (6 mt max)
I - Nude capillary AISI304, 36.37" max (6 mt max)	6 - Capillary AISI316 st.st., AISI316 st.st. armoured, 36.37" max (6 mt max)

FILLING FLUIDS and process fluid temperature

Fluid	Vacuum	Pressure	Fluid	Vacuum	Pressure
Standard silicon oil	-40...+122°F (-40...+100°C)	-40...+302°F (-40...+150°C)	E - Fluorinated liquid "E"	-40...+212°F (-40...+100°C)	-40...+302°F (-40...+150°C)
B - Silicon oil "B"	-40...+302°F (-40...+150°C)	-40...+482°F (-40...+250°C)	F - Silicon oil "C"	-130...+176°F (-90...+80°C)	-130...+302°F (-90...+150°C)
C - Silicon oil "C"	-14...+392°F (-10...+200°C)	-14...+662°F (-10...+350°C)	G - Mineral food oil "G"	-14...+302°F (-10...+150°C)	-14...+392°F (-10...+200°C)
D - Silicon oil "D"	-14...+392°F (-10...+200°C)	-14...+752°F (-10...+400°C)			

OPTIONS

C05 - Helium Test	P04 - Dye penetrant test
--------------------------	---------------------------------

"HOW TO ORDER" SEQUENCE

Section/Model/Connection material/Diaphragm material/Process Connection/Instrument connection/Assembling/Options

4 R00 4,5 4,9 --- 41F - G 1/2 F D B...G
1, 9, 6 C05, P04

IN ORDER TO IMPROVE THEIR PRODUCTION, MESSRS. NUOVA FIMA RESERVE THE RIGHT TO THEMSELVES TO MAKE ALL THE MODIFICATIONS THAT THEY DEEM INDISPENSABLE AT ANY TIME. UPDATED DATA SHEETS ARE AVAILABLE ON SITE: www.nuovafima.com



plastic diaphragm seal, with threaded connection



Diaphragm seals are designed to isolate the sensing element of pressure gauges, pressure switches and electronic pressure transmitter from process fluids which may be corrosive, viscous, sedimentous. An elastic diaphragm, mechanically clamped, fitted to a leak proof check, guarantees the separation of the process fluid from the transmission fill fluid. The corrosion is prevented by the assembling without bolts and nuts. Typical applications are: galvanic and water treatments, irrigation, electronic boards production.

4.P10 - MGS9/P10 - for pressure gauges \geq DN 4" (100mm)

Working pressure and temperature: see table below.

Accuracy (1): (add to instrument accuracy) $\pm 1,0\%$ for direct mounting.

Instrument connection: G 1/2.

Process connection: G 1/2, 1/2" NPT F.

Body Material :

V - PVC.

Diaphragm material :

A - PTFE.

Filling liquid: silicon oil.

4.P63 - MGS9/P63 - for pressure gauges DN 2.5" (63mm)

Working pressure and temperature: see table below.

Accuracy (1): (add to instrument accuracy) $\pm 1,0\%$ for direct mounting.

Instrument connection: G 1/4.

Process connection: G 1/4, 1/4" NPT F.

Body Material :

V - PVC.

Diaphragm material :

A - PTFE.

Filling liquid: silicon oil.

Process fluid temperature		
68 °F (20 °C)	104 °F (40 °C)	140 °F (60 °C)
150 psi (10 bar)	75 psi (5 bar)	15 psi (1 bar)

(1) at 68°F (20 °C) process temperature (or state temperature when ordering)

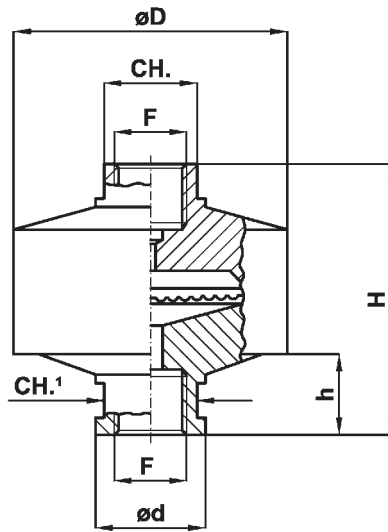

Model	F	D	d	H	h	CH ₁	CH
P10	41F - G 1/2	3.13 (79,5)	1.26 (32)	3.09 (78,5)	0.93 (23,5)	1.06 (27)	1.06 (27)
	43F - 1/2-14 NPT F						
P63	21F - G 1/4	2.34 (59,5)	0.98 (25)	2.54 (64,5)	0.77 (19,5)	0.87 (22)	0.67 (17)
	23F - 1/4-18 NPT F						

dimensions : inches (mm)

ASSEMBLING

D - Direct to instrument. All diaphragm seals are mounted on the instruments ad fixed by an aluminium protection label.

OPTIONS

Model	MGS9/P10	MGS9/P63
E - Fluorinated liquid "E" for process fluid temperature <i>from -40°F to +302°F</i> (from -40°C +150°C)	◆	◆
G - Food oil "G" for process fluid temperature <i>from -4°F to +392°F</i> (-20°C a + 200°C)	◆	◆

"HOW TO ORDER" SEQUENCE

Section/Model/Connection material/Diaphragm material/Process Connection/Instrument connection/Assembling/Options
4 P10 V A 41F 41F - G 1/2 F D E, G
P63 43F 21F 23F 21F - G 1/4 F

NUOVA FIMA

NUOVA FIMA S.r.l.

P.O. BOX 58 Via Cesare Battisti, 59

28045 Inverio (NO) Italy

Tel. +39 0322.253200

Fax +39 0322.253232

info@nuovafima.com

www.nuovafima.com